

**KINGDOM OF SAUDI ARABIA  
SAUDI STANDARDS, METROLOGY AND QUALITY ORGANIZATION**

**SASO**

---

**SAUDI STANDARD  
DRAFT No19965 /2011  
EDISON SCREW LAMPHOLDERS**

---

**SAUDI STANDARDS, METROLOGY AND QUALITY ORGANIZATION**

---

THIS DOCUMENT IS A DRAFT SAUDI STANDARD CIRCULATED FOR COMMENT. IT IS, THEREFORE SUBJECT TO CHANGE AND MAY NOT BE REFERRED TO AS A SAUDI STANDARD UNTIL APPROVED BY THE BOARD OF DIRECTORS.

## CONTENTS

introduction .....	<b>Error! Bookmark not defined.</b>
1 General .....	6
2 Definitions .....	9
3 General requirement .....	14
4 General conditions for tests.....	14
5 Standard ratings .....	18
6 Classification .....	20
7 Marking .....	22
8 Dimensions.....	26
9 Protection against electric shock .....	29
10 Terminals .....	33
11 Provision for earthing.....	41
12 Construction .....	43
13 Switched lampholders .....	54
14 Moisture resistance, insulation resistance and electric strength .....	57
15 Mechanical strength.....	61
16 Screws, current-carrying parts and connections.....	69
17 Creepage distances and clearances .....	73
18 Normal operation .....	76
19 General resistance to heat .....	77
20 Resistance to heat, fire and tracking.....	83
21 Resistance to excessive residual stresses (season cracking) and to rusting .....	87
Annex A (normative) Season cracking/corrosion test .....	89
Annex B (informative) Guidance for requirements in IEC 61058-1 applicable to switches in lampholders (see 13.2) .....	92
Annex C (informative) Guidance for special requirements in appliance standards – Household and similar electrical appliances .....	94
Figure 1a – Nipple thread for lampholders. Basic profile and design profile for the nut and for the screw .....	97
Figure 1b – Nipple thread for lampholders. Basic profile and design profile for the nut and for the screw .....	98
Figure 2a – Gauges for metric ISO thread for nipples .....	100
Figure 2b – Gauges for ISO standard pipe thread for nipples.....	101
Figure 3 – Gauge for holes for backplate lampholder screws .....	102
Figure 4 – Normal operation test apparatus.....	103
Figure 5 – Test caps for the test of clause 18.....	104

Figure 6 – Torque apparatus.....105  
Figure 7 – Tumbling barrel.....106

Figure 8 – Impact-test apparatus.....	107
Figure 8a – Mounting support .....	107
Figure 9 – Pressure apparatus.....	108
Figure 10 – Ball-pressure test apparatus.....	108
Figure 11 – Test cap for the tests of 14.4 and 19.3.....	109
Figure 12 – Bending apparatus .....	110
Figure 13 – Test cap A and test cap B for lampholders E14 .....	111
Figure 13 – Test cap A and test cap B for lampholders E14 ( <i>continued</i> ).....	112
Figure 14 – Test cap for lampholders E27 .....	113
Figure 15 – Test cap for lampholders E40 .....	114
Figure 16 – Standard test finger (according to IEC 60529).....	115
Figure 17 – Clarification of some definitions .....	116
Figure 18 – Preparation of specimens for the needle-flame test of 20.4 .....	117
Table 1 – Thickness of screw shells and contacts.....	27
Table 2 – Minimum effective screw lengths .....	27
Table 3 – Dimensions of threaded entries and set screws.....	29
Table 4 – Minimum dimensions of pillar-type terminals .....	37
Table 5 – Minimum dimensions of screw-type terminals.....	38
Table 6 – Pull and torque values .....	49
Table 7 – Insertion torque .....	53
Table 8 – Minimum and maximum removal torques.....	53
Table 9 – Test cap dimensions.....	62
Table 10 – Heights of fall .....	65
Table 11 – Maximum deformation values.....	68
Table 12 – Torque values .....	71
Table 13a – Minimum distances for a.c. (50/60 Hz) sinusoidal voltages Impulse withstand category II.....	75
Table 13b – Minimum distances for a.c. (50/60 Hz) sinusoidal voltages Impulse withstand category III.....	75
Table 14 – Minimum distances for non-sinusoidal pulse voltages.....	76
Table 15 – Heating cabinet temperatures .....	81
Table A.1 – pH adjustment.....	89

**INTRODUCTION**

The Saudi Standards ,Metrology and Quality Organization (SASO) has adopted the International Standard IEC 60238 Ed8.1/2008 “EDISON SCREW LAMPHOLDERS” issued by the International Electro technical Commission (IEC). It has been adopted without any technical modifications with a view to its approval as a Saudi standard.

**EDISON SCREW LAMP HOLDERS****1 General****1.1 Scope**

This International Standard applies to lampholders with Edison thread E14, E27 and E40, designed for connection to the supply of lamps and semi-luminaires\* only.

It also applies to switched-lampholders for use in a.c. circuits only, where the working voltage does not exceed 250 V r.m.s.

This standard also applies to lampholders with Edison thread E5 designed for connection to the supply mains of series connected lamps, with a working voltage not exceeding 25 V, to be used indoors, and to lampholders with Edison thread E10 designed for connection to the supply mains of series connected lamps, with a working voltage not exceeding 60 V, to be used indoors or outdoors. It also applies to lampholders E10 for building-in, for the connection of single lamps to the supply. These lampholders are not intended for retail sale.

As far as it reasonably applies, this standard also covers lampholders other than lampholders with Edison thread designed for connection of series-connected lamps to the supply.

NOTE This type of lampholder is for example used in Christmas tree lighting chains.

As far as it reasonably applies, this standard also covers adapters.

This standard also covers lampholders which are, wholly or partly, integral with a luminaire or intended to be built into appliances. It covers the requirements for the lampholder only. For all other requirements, such as protection against electric shock in the area of the terminals or of the lamp cap, the requirements of the relevant appliance standard shall be observed and tested after building into the appropriate equipment, when that equipment is tested according to its own standard. Such lampholders as well as lampholders provided with a snap-on outer shell, for use by luminaire manufacturers only, are not for retail sale.

This standard applies to lampholders to be used indoors or outdoors in residential as well as in industrial lighting installations. It also applies to candle lampholders. In locations where special conditions prevail, as for street lighting, on board ships, in vehicles and in hazardous locations, e.g. where explosions are liable to occur, special constructions may be required.

NOTE 1 This standard does not apply to three-light lampholders E26d.

NOTE 2 This standard is based on the following data relative to lamps for general lighting service:

- caps E14 are used for lamps with a current not exceeding 2 A;
- caps E27 are used for lamps with a current not exceeding 4 A;

---

\* Requirements for lampholders suitable for semi-luminaires are under consideration.

– caps E40 are used for lamps with a current not exceeding 16 A.

NOTE 3 If the nominal voltage of the supply does not exceed 130 V, the maximum current for caps E40 is 32 A (see 4.5 and 5.3).

NOTE 4 Where lampholders are used in luminaires, their maximum operating temperatures are specified in IEC 60598.

## 1.2 Normative references

The following referenced documents are indispensable for the application of this document. For dated references, only the edition cited applies. For undated references, the latest edition of the referenced document (including any amendments) applies.

NOTE With regard to IEC 60598-1, the references cited in this document are liable to change.

IEC 60061 (all parts), *Lamp caps and holders together with gauges for the control of interchangeability and safety*

IEC 60061-1: *Lamp caps and holders together with gauges for the control of interchangeability and safety – Part 1: Lamp caps*

IEC 60061-2: *Lamp caps and holders together with gauges for the control of interchangeability and safety – Part 2: Lampholders*

IEC 60061-3: *Lamp caps and holders together with gauges for the control of interchangeability and safety – Part 3: Gauges*

IEC 60068-2-20:1979, *Environmental testing – Part 2: Tests – Test T: Soldering*

IEC 60068-2-32:1975, *Environmental testing – Part 2: Tests – Test Ed: Free fall*

IEC 60068-2-75:1997, *Environmental testing – Part 2: Tests – Test Eh: Hammer tests*

IEC 60112:1979, *Method for determining the comparative and the proof tracking indices of solid insulating materials under moist conditions*

IEC 60227 (all parts), *Polyvinyl chloride insulated cables of rated voltages up to and including 450/750 V*

IEC 60245 (all parts), *Rubber insulated cables – Rated voltages up to and including 450/750 V*

IEC 60335-1:2001, *Household and similar electrical appliances – Safety – Part 1: General requirements*

IEC 60352-1:1997, *Solderless connections – Part 1: Wrapped connections – General requirements, test methods and practical guidance*

IEC 60399, *Barrel thread for lampholders with shade holder ring*

IEC 60417-DB:2002\*\*) *Graphical symbols for use on equipment*

IEC 60529:1989, *Degrees of protection provided by enclosures (IP Code) \**  
Amendment 1 (1999)

IEC 60598 (all parts and sections), *Luminaires*

IEC 60598-1: *Luminaires – Part 1: General requirements and tests*

IEC 60664-1:1992, *Insulation coordination for equipment within low-voltage systems – Part 1: Principles, requirements and tests \*\*\*)*

---

\*) A consolidated edition 2.1 (2001) exists including edition 2.0 (1989) and its amendment 1 (1999).

\*\*) "DB" refers to the IEC on-line database.

\*\*\*) A consolidated edition 1.2 (2002) exists including edition 1.0 (1992) and its amendment 1 (2000) and amendment 2 (2002).

Amendment 1 (2000)

Amendment 2 (2002)

IEC 60695-2-10:2000, *Fire hazard testing – Part 2–10: Glowing/hot-wire based test methods – Glow-wire apparatus and common test procedure*

IEC 60695-2-11:2000, *Fire hazard testing – Part 2-11: Glowing/hot-wire based test methods – Glow-wire flammability test method for end products*

IEC 60695-11-5:2004, *Fire hazard testing – Part 11-5: Test flames – Needle-flame test method – Apparatus, confirmatory test arrangement and guidance*

IEC 61058-1:2000, *Switches for appliances – Part 1: General requirements*

ISO 4046-4:2002, *Paper, board, pulps and related terms – Vocabulary – Part 4: Paper and board grades and converted products*

## 2 Definitions

For the purpose of this International Standard, the following definitions apply. For clarification of some definitions, see also figure 17.

### 2.1

#### **cord-grip lampholder**

a lampholder incorporating a method of retaining a flexible cord by which it may then be suspended

### 2.2

#### **threaded entry lampholder**

a lampholder incorporating a threaded component at the point of entry of the supply wires permitting the lampholder to be mounted on a mating threaded support (formerly called "nipple lampholder")

### 2.3

#### **backplate lampholder**

a lampholder so designed as to be suitable for mounting by means of an associated or integral back plate, directly onto a supporting surface or appropriate box

### 2.4

#### **lampholder for building-in**

a lampholder designed to be built into a luminaire, an additional enclosure or the like

#### 2.4.1

##### **unenclosed lampholder**

a lampholder for building-in so designed that it requires additional means, for example an enclosure, to meet the requirements of this standard with regard to protection against electric shock

**2.4.2****enclosed lampholder**

a lampholder for building-in so designed that on its own it fulfils the requirements of this standard with regard to protection against electric shock and IP classification, if appropriate

**2.5****independent lampholder**

a lampholder so designed that it can be mounted separately from a luminaire and at the same time providing all the necessary protection according to its classification and marking

**2.6****terminal/contact assembly**

a part or assembly of parts which provide(s) a means of connection between the termination of a supply conductor and the contact making surfaces of the corresponding lamp cap

**2.7****outer shell**

a cylindrical component protecting the user from contact with the lamp cap. It may or may not be provided with an external screw thread for fixing a shade ring

**2.7.1****snap-on outer shell**

an outer shell for screwless assembly which does not contain the screw shell

NOTE The lampholder should not be used when the snap-on outer shell is removed.

It is therefore recommended to place an approval mark, if provided, in such a way that it is not visible when this type of outer shell is removed.

**2.8****screw shell**

a cylindrical component having an internal screw thread of Edison form for the retention of the corresponding lamp (cap)

In some constructions, the screw shell is permanently fixed to or integral with the outer shell.

**2.9****insulating ring**

a cylindrical intermediate piece of insulating material separating a metal screw shell and a metal outer shell

**2.10****shade ring**

a cylindrical component having an internal thread or other means to engage a corresponding support on the outer shell and intended to carry or retain a shade

**2.11****dome**

a part of a cord-grip lampholder or threaded entry lampholder which shields the connecting terminals

**2.12****basic insulation**

an insulation applied to live parts to provide basic protection against electric shock

NOTE Basic insulation does not necessarily include insulation used exclusively for functional purposes.

**2.13****supplementary insulation**

an independent insulation applied in addition to basic insulation in order to provide protection against electric shock in the event of a failure of basic insulation

**2.14****double insulation**

an insulation comprising both basic insulation and supplementary insulation

**2.15****reinforced insulation**

a single insulation system applied to live parts, which provides a degree of protection against electric shock equivalent to double insulation under the conditions specified

NOTE The term "insulation system" does not imply that the insulation must be one homogeneous piece. It may comprise several layers which cannot be tested singly as supplementary or basic insulation.

**2.16****live part**

a conductive part which may cause an electric shock

**2.17****type test**

a test or series of tests made on a type test sample, for the purpose of checking compliance of the design of a given product with the requirements of the relevant standard

**2.18****type test sample**

a sample consisting of one or more similar specimens submitted by the manufacturer or responsible vendor for the purpose of a type test

**2.19****semi-luminaire**

a unit similar to a self-ballasted lamp but designed to utilize a replaceable light source and/or starting device

**2.20****rated operating temperature**

the highest temperature for which the holder is designed

**2.21****rated minimum temperature**

the lowest temperature for which the holder is designed (applicable only to lampholders intended for use in refrigerators and food freezers)

**2.22****angled lampholder**

lampholder, the rear side of which (threaded entry and/or dome) is at an angled position to the screw shell axis

**2.23****lampholder with retention device**

lampholder with a device intended to prevent the lamp from becoming loose in the holder

NOTE Lamps may, for example, become loose due to changes in temperature or to vibrations.

**2.24****impulse withstand categories**

a numeral defining a transient overvoltage condition

NOTE Impulse withstand categories I, II, III and IV are used.

a) Purpose of classification of impulse withstand categories

Impulse withstand categories are to distinguish different degrees of availability of equipment with regard to required expectations on continuity of service and on an acceptable risk of failure.

By selection of impulse withstand levels of equipment insulation co-ordination can be achieved in the whole installation, reducing the risk of failure to an acceptable level providing a basis for overvoltage control.

A higher characteristic numeral of an impulse withstand category indicates a higher specific impulse withstand of the equipment and offers a wider choice of methods for overvoltage control.

The concept of impulse withstand categories is used for equipment energized directly from the mains.

b) – Description of impulse withstand categories

Equipment of impulse withstand category I is equipment which is intended to be connected to the fixed electrical installations of buildings. Protective means are taken outside the equipment – either in the fixed installation or between the fixed installation and the equipment – to limit transient overvoltages to the specific level.

Equipment of impulse withstand category II is equipment to be connected to the fixed electrical installations of buildings.

Equipment of impulse withstand category III is equipment which is part of the fixed electrical installations and other equipment where a higher degree of availability is expected.

Equipment of impulse withstand category IV is for use at or in the proximity of the origin of the electrical installations of buildings upstream of the main distribution board.

## **2.25**

### **primary circuit**

a circuit which is directly connected to the AC mains supply. It includes, for example, the means for connection to the AC mains supply, the primary windings of transformers, motors and other loading devices

## **2.26**

### **secondary circuit**

a circuit which has no direct connection to a primary circuit and derives its power from a transformer, converter or equivalent isolation device, or from a battery

Exception: autotransformers. Although having direct connection to a primary circuit, the tapped part of them is also deemed to be a secondary circuit in the sense of this definition.

NOTE Mains transients in such a circuit are attenuated by the corresponding primary windings. Also inductive ballasts reduce the mains transient voltage height. Therefore, components located after a primary circuit or after an inductive ballast can be suited for an impulse withstand category of one step lower, i.e. for impulse withstand category II.

## **2.27**

### **adapter**

a component used for the electrical and mechanical connection of a lamp to a lampholder

NOTE This definition is specific for this standard. The definition of an adapter in principle could vary very much depending on its use. In most cases such a component is used to bridge differences in the screw thread diameter between the lampholder and the lamp.

## **3 General requirement**

Lampholders shall be so designed and constructed that in normal use they function reliably and cause no danger to persons or surroundings.

*In general, compliance is checked by carrying out all the tests specified.*

In addition, the enclosure of independent lampholders shall comply with the requirements of IEC 60598-1, including the classification and marking requirements of that standard.

## **4 General conditions for tests**

**4.1** Tests according to this standard are type tests.

NOTE The requirements and tolerances permitted by this standard are related to testing of a type test sample submitted for that purpose.

Compliance of the type test sample does not ensure compliance of the whole production of a manufacturer with this safety standard.

In addition to type testing, conformity of production is the responsibility of the manufacturer and may include routine tests and quality assurance.

For further information see IEC 60061-4<sup>\*\*\*\*</sup>) (inclusion of guidance on conformity testing during manufacture is in preparation).

---

<sup>\*\*\*\*</sup>) IEC 60061-4: *Lamp caps and holders together with gauges for the control of interchangeability and safety – Part 4: Guidelines and general information*

**4.2** Unless otherwise specified, the tests are made at an ambient temperature of  $20\text{ }^{\circ}\text{C} \pm 5\text{ }^{\circ}\text{C}$  and with the holder tested as delivered and installed as in normal use.

**4.3** The tests and inspections are carried out on a total of

- nine specimens for non-switched lampholders, or
- 12 specimens for switched lampholders

*in the following order of clauses:*

- three specimens clauses 1 to 12 (except for 9.1 and 10.2) and 14 to 17;
- three specimens clause 13 (switched-lampholder tests only);
- three specimens subclause 9.1 and clauses 18 and 19;
- two specimens clause 20 (of which one specimen for the test of 20.1 and the other for the tests of 20.3 or 20.4);
- one specimen 20.5 and clause 21.

For testing lampholders with a retention device, the retention device shall be removed.

For testing lampholders with a retention device according to 12.14, three additional specimens are required with the retention device kept in place.

**NOTE** For testing of screwless terminals according to 10.2, separate specimens are required in addition.

**4.4** *In case of doubt, gauges, test caps and mandrels are introduced into the specimens, unless otherwise specified, by applying the following torques:*

- 0,2 Nm for lampholders E5;
- 0,2 Nm for lampholders E10;
- 0,2 Nm for lampholders E14;
- 0,4 Nm for lampholders E27;
- 0,8 Nm for lampholders E40.

**4.5** *For lampholders E40 with a rated current of 32 A, the tests shall be based on this rated current.*

**4.6** *Lampholders are deemed to comply with this standard if no specimen fails in the complete series of tests specified in 4.3.*

*If one specimen fails in one test, that test and the preceding ones which may have influenced the result of that test are repeated on another set of specimens to the number required by 4.3, all of which shall then comply with the repeated tests and with the subsequent tests. Lampholders are deemed not to comply with this standard if there are more failures than one.*

**NOTE** In general, it will only be necessary to repeat the relevant test unless the specimen fails in the tests according to clauses 18 and 19, or if failure occurs with regard to resilient side or central contact(s); in these cases, both tests are repeated with a second set of three specimens.

The applicant may submit, together with the first set of specimens, the additional set which may be wanted in case of failure of one specimen. The testing station shall then, without further request, test the additional specimens and will reject only if a further failure occurs.

If the additional set of specimens is not submitted at the same time, a failure of one specimen entails a rejection.

## 5 Standard ratings

### 5.1 Standard rated voltages are 250 V and 500 V.

For lampholders E14, and for switched lampholders E27, a rated voltage of 250 V only is allowed.

For lampholders E5 and E10 intended for the connection of series-connected lamps to the supply, the rated voltage shall not exceed 25 V for lampholders E5 and not exceed 60 V for lampholders E10.

NOTE These values refer to the voltage between parts of different polarity.

For lampholders E10 intended for the connection of single lamps to the supply, a rated voltage of 250 V only is allowed.

NOTE These lampholders should also be used for such special cases as series-connected lamps, whereby the low number of lamps 60 V per lampholder is exceeded.

With the exception given for lampholders E5 and E10 the rated voltage shall be not less than 250 V. Additionally a rated voltage of 125 V is allowed for lampholders E40.

*Compliance is checked by inspection of the marking.*

### 5.2 Standard rated currents are

- 0,2 A for lampholders E5;
- 0,5 A for lampholders E10;
- 2 A for lampholders E14;
- 2 A for switched-lampholders E27;
- 4 A for other lampholders E27;
- 16 A for lampholders E40.

The rated current shall be not less than the standard value.

*Compliance is checked by inspection of the marking.*

**5.3** Lampholders E40 to be used on 125 V (see note) installations may have an additional nominal rating of 32 A.

NOTE This nominal rating covers the voltages up to and including 130 V.

*Compliance is checked by inspection of the marking.*

**5.4** The rated operating temperature for lampholders intended for use in high temperature conditions (T marked holders) shall be not lower than 140 °C for E14 lampholders, not lower than 170 °C for E27 lampholders and not lower than 230 °C for lampholders E40.

NOTE The values of the temperature marking should be increased by steps of 10 °C.

*Compliance is checked by inspection of the marking.*

NOTE The rated operating temperatures for Edison screw lampholders without T marking are given in IEC 60598-1, table 12.1. They are

- 135 °C for lampholders E14;
- 165 °C for lampholders E27;
- 225 °C for lampholders E40.

## 6 Classification

Lampholders are classified:

### 6.1 According to the material of the external parts:

- lampholders of insulating material;
- metal lampholders.

NOTE Lampholders with external parts consisting partly of metal and lampholders comprising external parts of insulating material with a conductive outer surface, for example a metallized outer shell, are considered as metal lampholders (see 12.3). This does not apply to threaded entries and external parts, as for example a metal shade ring mounted onto the outside of a lampholder of insulating material, which cannot become live even in the case of an insulation fault. Metal holders with insulating coverings are considered as metal lampholders (see 9.5).

*In order to check whether or not a surface is conductive, two stripe-electrodes 1,5 mm wide, 25 mm long and with a distance of 2 mm from each other are applied to the surface (e.g. with silver conductive paint). In accordance with 14.4, the insulating resistance is measured between the stripes. The surface is considered to be conductive if the resistance is less than 5 M $\Omega$ .*

### 6.2 According to degree of protection against ingress of water:

- ordinary lampholders;
- drip-proof lampholders.

### 6.3 According to method of fixing:

- threaded entry lampholders;
- cord-grip lampholders;
- backplate lampholders;
- other lampholders.

NOTE Examples of other lampholders are lampholders provided with a mechanical suspension device, e.g. a hook.

### 6.4 According to type:

- switched-lampholders, provided with an integral switch to control the supply to the lamp;
- non-switched lampholders.

### 6.5 According to protection against electric shock:

- unenclosed lampholders;
- enclosed lampholders;
- independent lampholders.

### 6.6 According to resistance to heat:

- lampholders for rated operating temperatures up to the limits given in 5.4;
- lampholders for operating in high temperature conditions (T marked holders).



## 7 Marking

7.1 Lampholders, other than lampholders E5 and E10, shall be marked with

- rated current, in amperes
- rated voltage, in volts, and rated pulse voltage, in kV, if higher than:
  - 2,5 kV for lampholders rated 250 V;
  - 4 kV for lampholders rated 500 V.

NOTE 1 The rated pulse voltage of the lampholder (in kV) should either be marked on the lampholder or made available in the manufacturer's catalogue or the like.

NOTE 2 Some lampholders still show rated voltages higher than 500 V. This is an earlier way of expressing the permissible pulse voltage via a rated voltage. For such lampholders, the creepage distances and clearances can be found in IEC 60598-1.

- symbol for nature of current, if required, (for switched lampholders only);
- mark of origin (this may take the form of a trade mark, manufacturer's identification mark or the name of the responsible vendor);
- type reference;
- the degree of protection against ingress of water for drip-proof lampholders (see 7.2);
- rated operating temperature "T", indicating the highest operating temperature, if applicable.

The marking of the rated operating temperature is not required for lampholders the exterior of which is made wholly of ceramic material. For these lampholders, this information, if applicable, shall either be marked on the lampholder or be made available in the manufacturer's catalogue.

For lampholders according to this standard, the distances for impulse withstand category II are usually applicable. For holders in equipment where a higher degree of availability is expected, distances for impulse withstand category III may be applicable. This information has to be indicated in the manufacturer's catalogue or the like.

Lampholders complying with the electrical strength test for double or reinforced insulation and having creepage distances and clearances equivalent to double or reinforced insulation offer an adequate level of protection for the use in luminaires where they are accessible in normal use. Such lampholders are addressed as lampholders for use in class II applications. This information shall be indicated in the manufacturer's catalogue or the like.

NOTE 3 Values for creepage distances and clearances as well as test voltages for the electrical strength test for double or reinforced insulation are given in IEC 60598-1.

To achieve sufficient creepage distances and clearances to outer accessible surfaces additional attachments could be used. In some cases, these dimensions might be achieved only after mounting the lampholder in the luminaire. Relevant information should be provided in the manufacturer's catalogue or the like.

Lampholders E10 shall be marked with

- rated voltage, in volts;
- mark of origin;
- type reference;
- the degree of protection against ingress of water, if applicable.

Lampholders E5 shall be marked with

- mark of origin;
- type reference.

*Compliance is checked by inspection.*

NOTE The type reference for lampholders E10 and E5 may be a catalogue number.

**7.2** If symbols are used for current and voltage, A shall denote amperes and V volts.

NOTE Alternatively, for volt and ampere ratings, figures may be used alone, the figure for the rated current being marked before or above that for the rated voltage and separated from the latter by an oblique stroke or line.

Therefore the marking of current and voltage may be as follows:

2 A 250 V or 2/250 or  $\frac{2}{250}$

The symbol for d.c. shall be  $\overline{\text{---}}$  (see IEC 60417-5031 (DB:2002-10)).

The symbol for protection against ingress of water for drip-proof lampholders shall be IPX1.

NOTE Where X is used in the IP number it indicates a missing numeral in the example, but both the appropriate numerals in accordance with IEC 60529 shall be marked.

The letter T shall be followed by the value of the rated operating temperature in degrees Celsius.

*Compliance is checked by inspection.*

**7.3** The marking of the degree of protection against ingress of water shall be on the outside of the holder.

*Compliance is checked by inspection.*

**7.4** An earthing terminal shall be indicated by the symbol  $\perp$  (see IEC 60417-5019 (DB:2002-10)).

This symbol shall not be placed on screws, removable washers or other easily removable parts.

*Compliance is checked by inspection.*

**7.5** Marking shall be durable and easily legible.

*Compliance is checked by inspection and, after the tests of clause 19 have been completed, by trying to remove the marking by rubbing lightly for 15 s with a piece of cloth soaked with water and for a further 15 s with a piece of cloth soaked with petroleum spirit.*

*After the tests the marking shall be still legible.*

NOTE The petroleum spirit used should consist of a solvent hexane with a content of aromatics of maximum 0,1 volume percentage, a kauri-butanol value of 29, an initial boiling-point of approximately 65 °C, a dry-point of approximately 69 °C and a specific density of approximately 0,68 g/cm<sup>3</sup>.

## 8 Dimensions

**8.1** Lampholders E10, E14, E27 and E40 shall comply with the current edition of the standard sheets of IEC 60061 series.

*Compliance shall be checked, by measuring in conformity with the current edition of IEC 60061-2, Standard Sheet 7005-20.*

*The minimum dimensions of the screw thread and dimension X shall be checked by means of gauges according to the current edition of Standard Sheets 7006-25 (E10, E14 and E40) and 7006-25A (E27), and by means of the gauge according to the current edition of Standard Sheet 7006-26 of IEC 60061-3.*

Lampholders designed with a barrel thread for shade holder rings and shade holder rings shall comply with IEC 60399.

*Compliance is checked by means of the gauges given in IEC 60399.*

**8.2** Lampholders shall allow insertion of all corresponding lamps so as to make contact.

*Compliance is checked by means of gauges according to the current edition of the following standard sheets of IEC 60061-3 and according to the indications of these sheets:*

- lampholders E14: 7006-30 and 7006-31;
- candle lampholders E14: 7006-30A and 7006-31;
- lampholders E27: 7006-21 and 7006-22A;
- lampholders E40: 7006-23 and 7006-24.

*Pending gauges for lampholders E5 and E10, the contact-making is checked by means of the corresponding lamps. It is presumed that the manufacturer of the lampholder for the purpose of the test delivers the lamps for which the lampholder is intended.*

*The checking of contact-making is done on lampholders as delivered and after the tests of clauses 18 and 19.2.*

For lampholders for use in appliances other than luminaires only:

If fixing means of lampholders are integrated parts of the rim and the lampholder is designed for use with a selected standardized lamp only, parts of the lampholder rim could interfere with the relevant contact-making gauge. In this case compliance with the requirements for maximum lamp outlines according to IEC 60630 for the lamp indicated in the lampholder manufacturer's instructions has to be checked. Following this checking the contact-making gauge shall be applied after those parts of the lampholder interfering with the gauge have been removed.

NOTE – For testing such lampholders, two additional specimen specially prepared to accept the relevant contact-making gauge, are required.

**8.3** The following dimensions shall be not less than the values shown in table 1.

**Table 1 – Thickness of screw shells and contacts**

<b>Thickness of the screw shell, if any, in mm:</b>	<b>E5</b>	<b>E10</b>	<b>E14</b>	<b>E27</b>	<b>E40</b>
– when the shell is unsupported	0,20	0,20	0,30	0,30	0,50
– when the shell is supported by insulating material over a total distance of at least three-quarters of the circumference of the shell	0,15	0,15	0,25	0,25	0,40
Thickness of side or central contacts, if resilient	0,18	0,18	0,28	0,38	0,48 *
* For the use of side-contacts in lampholders E40, see 12.11.					

*Compliance is checked by measurement.*

NOTE Thicknesses are measured by means of a micrometer with pointed noses and ratchet screw.

*For the screw shell, two sets of three measurements are made, each set carried out on one of two different generating lines of the screw shell. The mean value of the six measurements shall be at least equal to the specified value.*

NOTE The deletion of dimensional requirements is under consideration.

**8.4** The effective length of screw engagement, if any, of outer shell and dome shall meet one of the following requirements whereby the engagement shall always be over one full turn.

Either the effective length shall be not less than the values shown in table 2,

**Table 2 – Minimum effective screw lengths**

	<b>E14</b>	<b>E27</b>	<b>E40</b>
	mm	mm	mm
Metal lampholders:			
for rolled thread	5,0	7,0	10,0
for cut thread	5,0	5,0	7,0
Lampholders of insulating material	5,0	7,0	10,0

or the effective length shall be at least two turns provided the test according to 15.3 is withstood with a torque equal to 1,2 times the torque given in 15.2.

These requirements do not apply to lampholders E5 and E10.

*Compliance is checked by measurement.*

**8.5** The threaded entries of lampholders shall be provided with one of the following screw threads:

- lampholders E14: M10×1;
- lampholders E27: M10×1, M13×1 or M16×1;

- lampholders E40: M13×1, M16×1 (or G3/8A).

NOTE 1 The size between brackets is non-preferred; in addition, the threaded entry M10 is mainly intended for internal wiring of luminaires.

NOTE 2 In France, threaded entry lampholders with 11 mm × 19 TPI and 17 mm × 19 TPI (turns per inch) screw threads are permitted for replacement.

The thread of the entry shall comply with figures 1a or 1b.

These requirements do not apply to lampholders E5 and E10.

*Compliance is checked by measurement and by means of gauges according to figures 2a or 2b.*

*In case of doubt, the gauge is introduced into the entry by applying a torque of 0,5 Nm.*

**8.6** The dimensions of threaded entries and set screws, if any, shall be not less than the values shown in table 3.

**Table 3 – Dimensions of threaded entries and set screws**

<b>Nominal thread diameter</b>	<b>M10×1 M13×1 mm</b>	<b>M16×1 G3/8A mm</b>
Length of the thread:		
metal entry	3	8
entry of insulating material	5	10
Diameter of set-screw:		
screw with head	2,5	3,0
screw without head:		
– in case of one screw	3,0	4,0
– in case of more than one screw	3,0	3,0

A negative deviation of 0,15 mm from the nominal values for thread diameter is allowed.

*Compliance is checked by measurement.*

These requirements do not apply to lampholders E5 and E10.

**NOTE** If it is necessary to take the lampholder apart in order to check compliance with the requirements under 8.3 to 8.6, such checking is done after the test of clause 17.

**8.7** Lampholders shall be so designed that they do not interfere with the proper engagement or disengagement of lamps, even if the lamp cap is slightly dented. In no case shall the holder contacts present a cutting edge to the lamp cap.

*Compliance is checked by the following test:*

*For lampholders E27, compliance shall be checked by means of a gauge according to the current edition of Standard Sheet 7006-22B of IEC 60061-3.*

*For lampholders other than E27, compliance shall be checked by inspection.*

## **9 Protection against electric shock**

**9.1** Lampholders E5, E10, E14 and E27 shall be so designed that the lamp caps are not accessible when they become live during insertion.

NOTE 1 Details for checking compliance regarding protection against accidental contact with live parts during insertion for lampholders E5 and E10 are under consideration. Due to that, lampholders E10 with a rated voltage exceeding 60 V are for sale to luminaire or other equipment manufacturers only.

For lampholders E10 with a rated voltage exceeding 60 V the protection against electric shock may be provided by measures taken in the luminaire or equipment where the lampholders are used.

Lampholders E40 shall be so designed that the lamp cap is not accessible when fully inserted.

Candle lampholders are tested without decorative cover, unless this cover cannot be removed without making the lampholders obviously useless.

Compliance is checked as follows:

- for lampholders E10, by means of corresponding lamps and the standard test finger, shown in figure 16. For the purpose of the test, the lampholder manufacturer shall provide the lamps for which the lampholder is intended;
- for lampholders E14, E27 and E40, by means of gauges according to the current edition of the following standard sheets of IEC 60061-3:
  - 7006-31 for lampholders E14;
  - 7006-22A for lampholders E27;
  - 7006-24 for lampholders E40.

NOTE 2 In order to ensure protection against electric shock during insertion on unused lampholders, the tests according to 9.1 are made on new specimens.

**9.2** The external parts of enclosed and independent lampholders shall be so designed that live parts of the lampholder ready for use and with a corresponding normal lamp inserted are not accessible.

Candle lampholders are tested without decorative cover, unless this cover cannot be removed without making the lampholder obviously useless.

*Compliance is checked by means of the standard test finger.*

*For the purpose of the test:*

- enclosed lampholders are mounted as in normal use, for example on a threaded support, or the like, if appropriate, and provided with the most unfavourable conductor size fitted for which the lampholders are intended;
- independent lampholders shall be mounted as in normal use on an appropriate plane surface.

*The standard test finger shown in figure 16 is applied in every possible position with a force of 10 N, an electrical indicator being used to show contact with live parts.*

*It is recommended that a voltage of not less than 40 V be used.*

NOTE Unenclosed lampholders are only tested after appropriate installation in a luminaire or other additional enclosure.

**9.3** Parts providing protection against accidental contact with the lamp cap shall be reliably secured so that they will not become detached when a tightly fitting lamp is removed, or when rotating the shade, if applicable.

*Compliance is checked by the following test:*

*The coupling between dome and outer shell is tightened initially with a torque equal to two-thirds of the torque test value specified below. The relevant parts are then*

*subjected to a torque during 1 min in an anticlockwise direction with the following test values:*

- 1 Nm for lampholders E14;
- 2 Nm for lampholders E27.

*The lampholder is mounted as in normal use and is tested first with and then without the appropriate test cap according to figure 13 (test cap B) or figure 14.*

*After the test, the parts providing protection against accidental contact with the lamp cap shall not have become dismantled.*

*It shall not be possible to dismantle lampholders E5 and E10 without the aid of a tool.*

Requirements for lampholders E40 are under consideration.

**9.4** Where provision is made for attaching a shade to the lampholder, it is fitted to the lampholder by separate means, such as a shade ring; it is not permitted to fix a shade between parts providing protection against electric shock.

*Compliance is checked by inspection.*

**9.5** The external parts of

- drip-proof lampholders;
- lampholders with a rated voltage of more than 250 V;
- switched-lampholders, and
- lampholders E5 and E10

shall be of insulating material, with the exception of threaded entries and of those parts which cannot become live even in the event of a fault.

Lacquer or enamel is not deemed to provide adequate protection for the purpose of this clause.

*Compliance is checked by inspection.*

NOTE 1 Parts which are separated from live parts by double or reinforced insulation are considered as parts which cannot become live in the event of a fault.

NOTE 2 An example of an external part which cannot become live, even in the event of a fault, is a metal shade ring mounted on the outside of an insulated lampholder.

NOTE 3 Switched-lampholders with external metal parts are permitted under the conditions of 12.3.

## **10 Terminals**

**10.1** Lampholders, other than those provided with connecting leads (tails), shall be provided with terminals which allow connection of conductors having the following nominal cross-sectional areas:

- 0,5 mm<sup>2</sup> to 0,75 mm<sup>2</sup> for lampholders E10;
- 0,5 mm<sup>2</sup> to 1,0 mm<sup>2</sup> for lampholders E14 and E27 with M10×1 threaded entry;
- 0,5 mm<sup>2</sup> to 2,5 mm<sup>2</sup> for other lampholders E27;

- 1,5 mm<sup>2</sup> to 4 mm<sup>2</sup> for lampholders E40 with a rated current of 16 A;
- 2,5 mm<sup>2</sup> to 6 mm<sup>2</sup> for lampholders E40 with a rated current of 32 A.

*Compliance is checked by inspection and by fitting conductors of the smallest and largest cross-sectional area specified. For cord-grip lampholders, lampholders E10, E14 and lampholders E27 with M10×1 threaded entry, stranded conductors are used; in all other cases the conductors are of the solid type.*

*Threaded entry lampholders are tested in a screwed conduit.*

NOTE Lampholders E27 with screwless terminals intended for use by luminaire or equipment manufacturers only need not fulfil the requirements for all the appropriate nominal cross-sectional areas.

## **10.2 Connections**

**10.2.1** Lampholders shall be provided with at least one of the following means of connection:

- screw type terminals;
- screwless terminals;
- tabs or pins for push-on connections;
- posts for wire wrapping;
- soldering lugs;
- connecting leads (tails).

Terminal screws and nuts shall have a metric ISO thread or a thread comparable in pitch and mechanical strength.

Conductors may be connected to E5, E10 and similar small lampholders by soldering, welding, crimping or other equally effective means.

Lampholders with screwless terminals, unless intended for sale to luminaire or equipment manufacturers, shall be provided with terminals which are equally satisfactory with both rigid (solid or stranded) conductors and flexible cables or cords.

*Compliance is checked by the tests of 10.2.2.*

**10.2.2** Terminals shall comply with the following requirements, with the restriction that the requirements referring to internal wiring relate to wiring inside independent holders and to wiring inside luminaires for holders for building-in.

*All terminal tests shall be made on separate specimens which have not been subjected to any other test:*

- *terminals with screw clamping shall comply with the requirements specified in 10.3 to 10.6 inclusive, and 10.8;*
- *screwless terminals shall comply with section 15 of IEC 60598-1, provided that the heating test is carried out at the rated operating temperature of the lampholder  $\pm 5$  °C;*
- *tabs or pins for push-on connections shall comply with section 15 of IEC 60598-1;*
- *posts for wire wrapping shall comply with IEC 60352-1. Wire wrapping applies only to single solid round wire for internal wiring;*

- *soldering lugs shall comply with the requirements for good solderability. Suitable requirements can be found in IEC 60068-2-20;*
- *connecting leads (tails) shall comply with the requirements prescribed in 10.10.*

**10.3** Terminals shall be fixed in such a way that they will not work loose when fastening or loosening the conductors.

*For screw terminals, compliance is checked by inspection and by fastening and loosening a conductor of the largest cross-sectional area specified in 10.1 10 times, the applied torque being two-thirds of the torque specified in section 14 of IEC 60598-1.*

NOTE Terminals may be prevented from working loose by fixing with one screw in a recess without appreciable play, or by other suitable means. Covering with sealing compound without other means of locking is not deemed to be sufficient.

**10.4** Screw terminals shall be so designed that they clamp the conductor between metal surfaces with sufficient contact pressure and without damage to the conductor. Terminals shall be so designed that they will prevent a conductor slipping out when the screws or nuts are tightened. They shall allow a conductor to be connected without special preparation (e.g. soldering of the strands of the conductor, use of cable lugs, formation of eyelets, etc.).

*Compliance is checked by inspection of the conductors after fitting according to 10.1 and after the test of 19.3.*

NOTE The conductors are considered to be damaged if they show deep or sharp indentations.

**10.5** Terminals of the pillar type shall have dimensions not less than those shown in table 4.

**Table 4 – Minimum dimensions of pillar-type terminals**

<b>Lampholder</b>	<b>Nominal thread diameter</b> mm	<b>Diameter of hole for conductor</b> mm	<b>Length of thread in pillar</b> mm
E10	2,5	2,5	1,8
E14	2,5	2,5	1,8
E27	2,5	2,5	1,8
E40	3,5	3,5	2,5

NOTE The diameter of the hole shall be not more than 0,6 mm larger than the diameter of the screw.

The length of the threaded part of the terminal screw shall be not less than the sum of the diameter of the hole for the conductor and the length of thread in the pillar.

NOTE The length of the thread of the pillar is measured to the point where the thread is broken by the pillar hole.

*Compliance is checked by measurement.*

**10.6** Screw terminals shall have dimensions not less than those shown in table 5.

**Table 5 – Minimum dimensions of screw-type terminals**

<b>Lampholder</b>	<b>Nominal thread diameter</b> mm	<b>Length of thread under the head</b> mm	<b>Length of thread in nut</b> mm	<b>Nominal difference between diameter of head and shank of screw</b> mm	<b>Height of head</b> mm
E10	2,5	4,0	1,5	2,5	1,4
E14	3,0	5,0	1,5	3,0	1,8
E27	3,5	5,0	1,5	3,5	2,0
E40	4,0	6,0	2,5	4,0	2,4

If an intermediate part locked against rotation, such as a washer or a pressure plate, is used between the head of the screw and the conductor, the difference in diameter between head and shank of the screw may be reduced by 1 mm.

*Compliance is checked by measurement.*

A negative deviation of 0,15 mm from then nominal values of the thread diameter and of the difference in diameter of head and shank is allowed.

NOTE If it is necessary to take the lampholder apart in order to check compliance with the requirements under 10.5 and 10.6, such checking is done after the test of clause 17.

**10.7** Terminals shall be so located that, after correct fitting of the wires, there is no risk of accidental contact between live parts and accessible metal parts.

*Compliance is checked by inspection and by the following test:*

*The insulation is removed over a length of 4 mm from the end of a flexible conductor having the minimum nominal cross-sectional area specified in 10.1. One wire of the stranded conductor is left free and the remainder are fully inserted into and clamped in the terminal of the lampholder, mounted and installed as in normal use (locking screws tightened, etc.).*

*The free wire is bent without tearing the insulation back, in every possible direction, but without making sharp bends around barriers.*

*The free wire of a conductor connected to a live terminal shall not touch any metal part which is not a live part, and that of a conductor connected to the earthing terminal shall not touch any live part.*

*If necessary, the test is repeated with the free wire in another position.*

NOTE The prohibition against making sharp bends around barriers does not imply that the free wire shall be kept straight during the test. Sharp bends are, moreover, made if it is considered likely that such bends can occur during the normal assembly of the lampholder. See also 12.3.

**10.8** Pillar terminals in which the end of the conductor is not visible shall have a length of hole beyond the terminal screw at least equal to half the value of the diameter of the screw or 2,5 mm, whichever is the higher.

*Compliance is checked by measurement.*

**10.9** Terminals which are floating shall show no appreciable lateral play and shall not move longitudinally more than 3 mm when a lamp is removed or inserted.

*Compliance is checked by measurement.*

**10.10** The requirements of 10.2 to 10.6 inclusive and of 10.8 do not apply to lampholders intended to be factory-mounted in luminaires and which are provided with connecting leads (tails).

Lampholders intended to be factory-mounted in luminaires or built into equipment may be provided with connecting leads (tails), tab-terminals or equally effective means.

Connecting leads (tails) shall be connected to the lampholders by soldering, welding, crimping or by any other at least equivalent method.

Leads shall consist of insulated conductors.

Insulation of the free end of the leads may be stripped.

Fixing of the leads to the lampholders shall withstand the mechanical forces that may occur in normal use.

*Compliance is checked by inspection and by the following test, which is made after the test of 19.2 on the same three specimens.*

*Each connecting lead is subjected to a pull of 20 N, the pull is applied without jerks for 1 min in the most unfavourable direction.*

*During the test leads shall not move from their fixing.*

*After the test, the lampholders shall show no damage within the meaning of this standard.*

## 11 Provision for earthing

**11.1** Threaded entry lampholders, cord-grip lampholders and backplate lampholders, with provisions for earthing, other than those provided with connecting leads, shall have at least one internal earthing terminal; other lampholders without threaded entry, for example, lampholders for building-in, may be provided with an external earthing terminal.

*Compliance is checked by inspection.*

NOTE Lampholders intended to be earthed but not provided with an earthing terminal or with connecting leads are not for retail sale.

**11.2** Accessible metal parts of lampholders without earthing terminal, which may become live in the event of an insulation fault, shall allow reliable earthing.

There shall be earth continuity between a metal dome and the outer shell, if of metal, when the shell is not separated from live parts by double or reinforced insulation.

NOTE For the purpose of this requirement, small isolated metal screws and the like for fixing bases or covers are not deemed to be accessible parts which may become live in the event of an insulation fault.

*Compliance is checked by the following test:*

*A rigid conductor having the smallest cross-sectional area for which the holder is intended is fitted to the earthing terminal, if provided.*

*When earth continuity between the dome and the outer shell also has to be checked, the coupling between these parts shall be tightened with the torque specified:*

- 1 Nm for lampholders E14;

- *2 Nm for lampholders E27;*
- *4 Nm for lampholders E40.*

*Immediately after the tests of 14.3, the resistance between the means of earthing and the dome (or the outer shell as appropriate) is measured.*

*For lampholders with an earthing terminal, the means of earthing is the point where the conductor leaves the terminal and for lampholders without an earthing terminal, it is the point where the earthing connection is intended to be made.*

*A current of at least 10 A, derived from a source with a no-load voltage not exceeding 12 V, shall be passed between the earthing terminal or earthing contact and each of the accessible metal parts in turn.*

*The voltage drop between the means of earthing and accessible metal part shall be measured. The resistance, calculated from the voltage drop and the current, shall not exceed 0,1  $\Omega$ .*

**11.3** Earthing terminals shall comply with the requirements of clause 10.

Their clamping means shall be adequately locked against accidental loosening, and it shall not be possible to loosen screw terminals by hand and screwless terminals unintentionally by hand.

*Compliance is checked by inspection and by the tests of clause 10.*

NOTE In general, the designs commonly used for current-carrying terminals (complying with the requirements of this standard) provide sufficient resilience to comply with the latter requirement; for other designs special provisions, such as the use of an adequate resilient part which is not likely to be removed inadvertently, may be necessary.

**11.4** The metal of earthing terminals shall be such that there is no risk of corrosion resulting from contact with the copper of the earthing conductor.

The screw or the body of the earthing terminal shall be of brass or other metal no less resistant to corrosion, and the contact surfaces shall be bare metal.

*Compliance is checked by inspection.*

NOTE The risk of corrosion is particularly great when copper is in contact with aluminium.

**11.5** Metal parts of the cord anchorage, including clamping screws, shall be insulated from the earthing circuit.

*Compliance is checked by inspection.*

## **12 Construction**

**12.1** Lampholders shall be provided with a screw thread of Edison form for holding the lamp.

For lampholders other than E5 and E10, this thread shall be either of metal and shall be continuous over a length not less than that specified in the current edition of standard sheet 7005-20 of IEC 60061-2, or comply with the following requirements.

NOTE The requirement for a minimum length of screw thread for lampholders E5 and E10 is under consideration.

Deviation from the requirements for a metal thread is allowed provided the design and production tolerances are such that proper engagement with all gauges is ensured throughout the life of the holder delivered. On this subject, further information will be available in the annex: Surveillance tests, under consideration.

In addition, the terminal/contact assembly and the screw shell shall be so constructed and located as to prevent canting or rotation which would impair the use of the lampholder.

Deviation from the requirement for a continuous thread is allowed if this is necessary to provide a special technical advantage, such as the inclusion of a lamp retention device in a cut-away.

*Compliance is checked by inspection and by a manual test with the relevant gauges, referred to in clause 8, applied in all positions which can be achieved with reasonable force, and the holder shall still comply with the gauges, especially the feeler gauge of 0,08 mm × 5,0 mm.*

*Furthermore, it shall not be possible to score the neck of the bulb of a lamp made to normal standards during engagement and disengagement.*

The male screw thread of an adapter shall be of the same size or larger than the female screw thread shell of the adapter.

**12.2** There shall be adequate space for the supply wires in the dome of the lampholder. Parts of the lampholder with which insulated conductors may come into contact shall have no sharp edges or a shape likely to damage the insulation.

Threaded entry lampholders shall be provided with means to prevent the conduit entering too far into the entry, unless it is evident from the design that the conduit is unlikely to enter too far into the entry, for example in certain candle lampholders.

*Compliance is checked by inspection and by fitting flexible cables or cords of the largest cross-sectional area according to 10.1 for lampholders E14 and lampholders E27 with M10×1 threaded entries, with conductors with a nominal cross-sectional area one size less than specified for other lampholders E27 and lampholders E40.*

*For cord-grip lampholders, lampholders E14 and lampholders E27 with M10×1 threaded entries, an ordinary sheathed flexible cord is used; in all other cases, two or three PVC insulated single-core cables are used.*

*For threaded entry lampholders, the dome of the lampholder is screwed onto a conduit having a length of about 10 cm. The cables are then introduced into the conduit and dome. The ends of the cables, after having been prepared in the usual manner, are connected to the terminals of the lampholder. If possible, the connection is made with the part carrying the terminals in a position where the shortest distance between the plane of the upper edge of the dome and the nearest part of the terminals is 10 mm. With the terminals held in this position, the cables are tightened and clamped at the free end of the conduit. After this, the lampholder is assembled.*

*After dismantling, the cables and cords shall not be damaged.*

NOTE 1 For lampholders E27 and E40, a test with conductors with maximum cross-sectional area according to 10.1 is under consideration.

NOTE 2 The requirement concerning sharp edges is not meant for the outer end of the threaded entry, since they are not in contact with the wires when the lampholder is mounted on a conduit.

*In case of doubt with regard to the means to prevent the conduit entering too far into the entry of a threaded entry lampholder, the lampholder is screwed onto a steel conduit or mandrel having squared ends (edges left sharp). The conduit or the mandrel is provided with a full thread having the minimum dimensions shown in figures 1a or 1b.*

*During this test, the following torque is applied for 1 min:*

- 1,0 Nm for threaded entries M10×1;
- 1,3 Nm for threaded entries M13×1;
- 1,6 Nm for threaded entries M16×1 and G3/8A.

*After this test, the conduit or the mandrel shall not have entered into the space provided for the supply wires in the dome of the lampholder, and the lampholder shall not show any change impairing its further use.*

**12.3** Accessible parts of switched lampholders shall be of insulating material unless the design is such that a live wire detached from its terminal cannot touch accessible metal parts or parts of the earthing circuit and that terminal screws or screws in threaded entries which have become loose cannot bridge accessible metal parts, including earthing terminals, and live parts.

*Compliance is checked by inspection.*

NOTE This requirement does not necessarily imply either complete or partial insulating lining.

**12.4** In case of lampholders with metal screw shell and metal outer shell, contact between these parts shall be prevented by an insulating ring which shall not be separable from the live parts or the metal outer shell by hand.

*Compliance is checked by inspection.*

NOTE The protection by the insulating ring is considered sufficient if its length is approximately equal to that of the screw shell.

**12.5** It shall be possible to lock the threaded entry on the conduit. Locking devices can either be part of the lampholder or be provided by the design of a luminaire.

Except for angled lampholders, it shall be possible to operate the locking device from the inside, if provided as part of the lampholder.

NOTE If such means are provided by the design of a luminaire, their efficiency cannot be checked when testing the lampholder; such a check should be made during testing of the luminaire. Such lampholders are not intended for retail sale.

This requirement does not apply to lampholders E5 and E10.

*Compliance is checked by inspection and, for lampholders having an integral locking device, by the test of 15.4.*

**12.6** Cord-grip lampholders and all lampholders designed for chain connection shall be provided with a device allowing the lampholder to be so fixed to a flexible cord that the conductors are relieved from strain, including twisting, where they are connected to the terminals, and that the outer covering of the cord is gripped in the lampholder and is protected from abrasion. It shall be clear how the relief from strain and the prevention of twisting is intended to be effected.

It shall not be possible to push the cord into the lampholder to such an extent that the cord is subjected to undue mechanical or thermal stress.

Makeshift precautions, such as tying the cord into a knot or tying the end with string, are not permissible.

The device shall be of insulating material or be provided with a fixed insulating lining if otherwise an insulation fault on the cord could make accessible metal parts live.

The design shall be such that the device:

- is at least one part fixed to or integral with the lampholder;
- is suitable for the different types of flexible cord which may be connected to the lampholder;
- does not exert excessive pressure on the cord;
- is unlikely to be damaged when it is tightened or loosened as in normal use.

The device shall be suitable for flexible cords of the following types:

60245 IEC 51;

60245 IEC 53 or the like;

60227 IEC 52.

*Compliance is checked by inspection and by the following test:*

*The lampholder is fitted with a flexible cord, the device for strain and twist relief being appropriately used. The conductors are introduced into the terminals and the terminal screws are slightly tightened, so that the conductors cannot easily change their position. After this preparation, it shall not be possible to push the cord further into the lampholder.*

*The flexible cord is then subjected 100 times to a pull of the appropriate value shown in the table below, each for a duration of 1 s. The pull shall not be applied in jerks.*

*Immediately afterwards, the flexible cord is subjected for a period of 1 min to a torque as specified in table 6.*

**Table 6 – Pull and torque values**

<b>Total nominal cross-sectional area of all conductors together mm<sup>2</sup></b>	<b>Pull N</b>	<b>Torque Nm</b>
Up to and including 1,5	60	0,15
Over 1,5 up to and including 3	60	0,25
Over 3 up to and including 5	80	0,35
Over 5 up to and including 8	120	0,35

*The lampholders are tested with each of the appropriate types of cord, as specified before, complying with IEC 60245 or IEC 60227.*

*The test is first made with conductors of the smallest cross-sectional area specified in 10.1 as well as with conductors of either the largest cross-sectional area allowed by the suspending device or the largest cross-sectional area specified in 10.1, whichever is the smaller.*

*For lampholders designed for chain connection, the test is carried out with the cables for which the lampholder is designed. The cable is subjected 50 times to a pull of 30 N. The torque test is not carried out.*

*During the test, no damage to the flexible cord shall be caused by the device for strain and twist relief. At the end of the test, the cord shall not have been displaced by more than 2 mm, and the ends of the conductors shall not have been noticeably displaced in the terminals.*

*In order to enable the displacement to be measured, before starting the test a mark is made on the cord under strain at a distance approximately 2 cm from the strain-relieving device. At the end of the test, the displacement of this mark in relation to the strain device is measured while the cord is still under strain.*

**12.7** Suspending devices of enclosed and independent lampholders shall have no accessible metal parts which can become alive, even in the event of a fault in the lampholder; moreover, suspending devices intended to be screwed into threaded entry lampholders shall comply with the requirements of 12.2.

*Compliance is checked by inspection and by the test of 12.6.*

**12.8** Backplate lampholders not specifically intended for building-in shall have a recess for supply wires. This recess shall have the following minimum dimensions in order to allow back entry from a conduit perpendicular to the mounting surface of the lampholder:

- height 7 mm;
- length equal to diameter or width of the base;
- width 16 mm enlarged to a circular space 23 mm in diameter in the centre.

*Compliance is checked by measurement.*

The dimensional requirement does not apply to lampholders E5 and E10.

**12.9** The base of backplate lampholders, other than those specifically intended for building-in, shall be suitable for fixing by means of screws with a diameter of at least 4 mm.

*Compliance is checked by means of a gauge according to figure 3. For this test, the plug is inserted into the hole from the back and the bush is placed on the plug from the front.*

*The bush shall enter the recess for the screw head.*

This requirement does not apply to lampholders E5 and E10.

**12.10** Where provision for cable entry/entries is made on the accessible external surface of a backplate lampholder, they shall allow the introduction of cable covering, conduit or trunking etc., as appropriate, so as to afford mechanical protection at least for a distance of 1 mm measured from the accessible external surface of the backplate lampholder.

*Compliance is checked by measurement and by the installation test of 10.1.*

**12.11** The contacts shall be designed and constructed so as to ensure during normal use effective and reliable electrical contact.

The functioning of the contacts shall be independent of the functioning of an optional locking device between the dome and the outer shell.

New E40 lampholder designs shall be of the contact-making shell type.

NOTE Contact-making problems with actual lamp caps have shown that the contact-making shell type is the only practical solution in this respect.

*Compliance is checked by inspection and by the test of 19.2.*

NOTE A single side-contact is allowed.

**12.12** Lampholders shall not be fitted with a socket-outlet.

*Compliance is checked by inspection.*

**12.13** Devices for bridging the lamp filament shall not be integral with the lampholder.

*Compliance is checked by inspection and, if necessary, by test.*

**12.14** Lampholders with a retention device shall be able to withstand a certain unscrewing torque.

A commercially available brass lamp cap complying with the relevant standard sheets shall be inserted into the sample lampholder with retention device, with a torque according to the type of lampholder as specified in table 7.

**Table 7 – Insertion torque**

Lamp cap	Torque Nm
E27	1,5 ± 0,1
E40	2,0 ± 0,1

The lamp is then unscrewed for about 30°. In this position, the removal torque is measured.

The removal torque shall not be less than the minimum value and shall not exceed the maximum value specified in table 8.

**Table 8 – Minimum and maximum removal torques**

Lamp cap	Minimum torque Nm	Maximum torque Nm
E27	0,5	2,0
E40	1,0	4,0

NOTE When the lamp cap is damaged or is showing wear, a new cap should be used for the tests.

**13 Switched lampholders**

**13.1** Switches are allowed only in ordinary lampholders E14 and in ordinary lampholders E27 for use up to and including 250 V.

*Compliance is checked by inspection.*

**13.2** Switched lampholders shall comply with the constructional requirements of 12.3 and with the additional requirements of 13.3 to 13.5, or with the relevant requirements given in IEC 61058-1.

NOTE Guidance for the selection of the relevant requirements in IEC 61058-1 is given in Annex B.

**13.3** Switches in lampholders shall be capable of making and breaking a load comprising a filament lamp or self-ballasted lamp for general lighting service (GLS).

*Compliance is checked by the following tests:*

*Switches in lampholders E14 shall be tested for an operating temperature of 100 °C, and switches in lampholders E27 shall be tested for an operating temperature of 125 °C.*

*Switches in lampholders intended for use in refrigerators or food freezers shall be tested at the rated operating temperatures.*

*Switches in lampholders with temperature marking shall be tested for operating temperatures as follows:*

- lampholders E14: the temperature marking of the lampholder minus 40 °C;*
- lampholders E27: the temperature marking of the lampholder minus 50 °C.*

*The switch is tested with a.c. ( $\cos \phi = 0,6 \pm 0,05$ ) at 1,1 times rated voltage and 1,25 times rated current.*

*The switch shall be operated in a normal manner for 200 switch movements at a rate of 30 movements per minute at regular intervals.*

*The switch is then tested with a.c. ( $\cos \phi = 1$ ) at rated voltage and rated current.*

*The switch shall be operated in a normal manner for 20 000 switch movements at a rate of 30 movements per minute at regular intervals.*

NOTE Replacement of the above test by the corresponding test of IEC 61058-1 is under consideration.

*At the conclusion of the test, the lampholder shall withstand the tests specified in 14.4 for insulation resistance and electric strength and shall be in satisfactory working order.*

**13.4** Switched lampholders shall be so constructed that accidental contact between moving parts of the switch and the supply wires is prevented.

*Compliance is checked by the test of 10.1 and by a manual test.*

**13.5** The switch-operating member shall be effectively insulated from live parts and, if it is broken or damaged, it shall not expose live parts.

*Compliance is checked by inspection and by the tests specified in 13.3.*

**13.6** Switches in lampholders intended for use in refrigerators or food freezers may be tested with a lamp according to the expected wattage rating for lamps of the appliance.

## 14 Moisture resistance, insulation resistance and electric strength

**14.1** The enclosure of drip-proof lampholders shall provide the necessary degree of protection against ingress of water.

*Compliance is checked by the following test.*

*Lampholders are fitted with the cables or conduits for which they are designed.*

*Backplate lampholders are mounted on a vertical surface with one drain hole, if any, open and directed downwards. Other lampholders are mounted with their lamp entry pointing vertically downwards.*

*The test is made by means of equipment, the principle of which is shown in figure 3 of IEC 60529; the rate of discharge shall be reasonably uniform over the whole area of the apparatus and shall produce a rainfall of between 3 mm and 5 mm of water per minute, falling vertically from a height of 200 mm measured from the lampholder. The test duration is 10 min. The water used for the test shall be at a temperature of 15 °C ± 10 °C.*

*Immediately after this treatment, the lampholder shall withstand the same electric strength test as specified in 14.4, and inspection shall show that water has not entered to an appreciable extent.*

**NOTE** It is considered that water has entered to an appreciable extent if it has come into contact with live parts. In this case, a screw shell which is only live when a lamp is inserted is not considered as a live part.

**14.2** Inlet openings of drip-proof lampholders shall allow the connection of the supply wires in such a way that drops of water running along the wires cannot reach the inside of the lampholder.

*Compliance is checked by inspection.*

**14.3** Lampholders shall be proof against humid conditions which may occur in normal use.

*Compliance is checked by the humidity treatment described in this subclause followed immediately by the measurement of the insulation resistance and by the electric strength test specified in 14.4.*

*Cable entries, if any, are left open; if knock-outs are provided, one of them is opened.*

*The humidity treatment is carried out in a humidity cabinet containing air with a relative humidity maintained between 91 % and 95 %. The temperature of the air, at all places where specimens can be located, is maintained within 1 °C of any convenient value  $t$  between 20 °C and 30 °C.*

*Before being placed in the humidity cabinet, the specimens are brought to a temperature between  $t$  and  $(t + 4)$  °C.*

*Lampholders are kept in the cabinet:*

- *two days (48 h) for ordinary lampholders;*
- *seven days (168 h) for IPX1 drip-proof lampholders.*

NOTE 1 In most cases, the specimens may be brought to the specified temperature by keeping them at this temperature for at least 4 h before the humidity treatment.

NOTE 2 Relative humidity between 91 % and 95 % can be obtained by placing in the humidity cabinet a saturated solution of sodium sulphate ( $\text{Na}_2\text{SO}_4$ ) or potassium nitrate ( $\text{KNO}_3$ ) in water, having a sufficiently large contact surface with the air. In order to achieve the specified conditions within the cabinet, it is necessary to ensure constant circulation of the air within and, in general, to use a cabinet which is thermally insulated.

*After this treatment, the lampholders shall show no damage within the meaning of this standard.*

**14.4** The insulation resistance and the electric strength shall be adequate:

- a) between live parts of different polarity;
- b) between such live parts and external metal parts, including fixing screws of the base or enclosure of backplate lampholders, and accessible assembling screws;
- c) between the inner and outer surfaces of the lining of metal enclosures, if such accessible lining is required in accordance with 12.3 to give protection or if the distance between any live part and the metal of the enclosure is smaller than that required under item 4) of 17.1.

*Compliance is checked by an insulation-resistance measurement and an electric strength test made immediately after the humidity treatment in the humidity cabinet, or in the room in which the specimens were brought to the prescribed temperature.*

*The insulation resistance is measured with a d.c. voltage of approximately 500 V, the measurement being made 1 min after application of the voltage.*

*The insulation resistance is measured consecutively:*

- a) *between live parts of different polarity;*
- b) *between such live parts connected together and the body;*
- c) *between accessible metal parts and metal foil in contact with the inner surface of insulating lining, if any.*

*The term "body" used in item b) includes external metal parts, fixing screws of the base and of the enclosure, accessible assembling screws and metal foil in contact with the surface of external insulating parts.*

*Measurements prescribed in items a) and b) are first made on the lampholder in which the test cap shown in figure 11 is inserted and then on the empty lampholder.*

*The switch, if any, is placed in the "on" position.*

*If metal foil is used for the test on the empty lampholder, it shall also be in contact with the metal screw shell if this shell has to be insulated from the contacts.*

*The insulation resistance shall be not less than:*

- *2 M $\Omega$  for the measurement according to item a);*
- *4 M $\Omega$  in all other cases.*

*Immediately after the insulation resistance test, an a.c. voltage of substantially sine-wave form, with a frequency of 50 Hz or 60 Hz and with an r.m.s. value of  $(2 U + 1 000)$  V (where U is the rated voltage) is applied for 1 min between the points*

*prescribed. Additionally, for switched lampholders, this voltage is applied between live parts of different polarity and other metal parts with the switch both closed and open.*

*The electric strength test voltage between live parts of different polarity for lampholders E5 and E10 with a rated voltage not exceeding 60 V is reduced to 500 V.*

*Initially, not more than half the prescribed voltage is applied, it is then raised rapidly to the full value.*

*No flashover or breakdown shall occur during the test.*

*The high-voltage transformer used for the test shall be so designed that, when the output terminals are short-circuited after the output voltage has been adjusted to the appropriate test voltage, the output current is at least 200 mA.*

*The overcurrent relay shall not trip when the output current is less than 100 mA.*

*Care is taken that the r.m.s. value of the test voltage applied is measured within  $\pm 3\%$ .*

*Glow discharges without drop in voltage are neglected.*

## **15 Mechanical strength**

**15.1** Lampholders shall have adequate mechanical strength and shall withstand the strain due to the insertion of a lamp as well as that caused by the screwing of the lampholder to a conduit.

*Compliance is checked by the tests of 15.2 to 15.7.*

NOTE With the exception of candle lampholders, brackets or similar devices for the mounting or attachment of lampholders are not covered by the requirements of this clause. The mechanical strength of such devices shall comply with the requirements of the standard for the equipment for which the lampholder is intended.

**15.2** The mechanical strength of the outer shell, the screw shell and the dome is checked by screwing a test cap into the specimen, the following torque being applied for 1 min:

- 0,3 Nm for lampholders E5;
- 0,3 Nm for lampholders E10;
- 0,5 Nm for candle lampholders E14, when the lampholder is fixed by the threaded entry;
- 1,2 Nm for candle lampholders E14, when the lampholder is clamped by the outer shell;
- 1,2 Nm for other lampholders E14;
- 2 Nm for lampholders E27;
- 4 Nm for lampholders E40.

*The test cap dimensions are as specified in table 9.*

Table 9 – Test cap dimensions

<b>Lampholder</b>	<b>Dimension S*</b> mm	<b>Diameter of central contact</b> mm
E14	5,5	4,8
E27	9,5	9,5
E40	11,0	14,0

\* For the meaning of dimension S, see figures 13, 14 or 15.

*The dimensions of the test caps for lampholders E5 and E10 are under consideration. For the time being, the test is carried out with a cap having the same dimensions as the cap of the lamp for which the lampholder is designed.*

*The test is made twice; first with the specimen clamped at the outer shell and secondly with the specimen fixed by the threaded entry, dome or backplate, according to type of lampholder.*

*At the end of the test, the specimen shall not show any change impairing its normal use.*

**15.3** The dome or backplate of the specimen is fixed and a torque as indicated under 15.2 is applied to the outer shell for 1 min so as to tighten the screwed connection between shell and dome.

*This test shall cause neither loosening of the connection between shell and dome nor any other damage.*

The test does not apply to lampholders E5 and E10.

**15.4** *The dome of threaded entry lampholders is fixed to a brass conduit in the normal way, the set-screws being tightened with a torque equal to the values indicated in the table of 16.1 and the locking of the screwed entry is tested by the application for 1 min of a torque as indicated under 15.2, but in an anti-clockwise direction.*

*The application of this torque shall not loosen the threaded entry from the brass conduit.*

*If, however, the threaded entry loosens, the set-screw is further tightened with the smallest torque necessary to prevent the entry from loosening during this test, and this minimum value is noted.*

NOTE It is practical to increase the torque by increments of about 20 % during this test.

*The minimum value of the torque applied is noted for the purpose of the test of 16.1.*

NOTE For the tests under 15.2 to 15.4, the use of an apparatus according to figure 6 is recommended.

**15.5** The strength of the connection between dome and threaded entry is checked as indicated in figure 12.

*The specimen is fixed by the threaded entry in a horizontal position. A mandrel with a thread having the maximum IEC dimensions acceptable for caps, and with other dimensions according to figure 12, is screwed into the lampholder and is loaded for 1 min with a mass, as indicated in figure 12. The end of the mandrel shall not sag more than 5 mm.*

*The specimen shall not be damaged. If a permanent deformation occurs, the specimen is forced into the original position and the test is repeated five times, after which the specimen shall show no damage impairing its normal use.*

This test does not apply to candle lampholders.

**15.6** The mechanical strength of the outer shell of insulating material with or without a conductive outer surface and of insulating rings between the screw shell and the exterior of metal lampholders is checked by means of the pendulum hammer test specified in IEC 60068-2-75, subject to the following details (see 3.9 of IEC 60068-2-75).

a) *Method of mounting:*

*The specimen shall be held against the plywood sheet of the mounting fixture in such a manner that its axis is horizontal and parallel to the support and its outer edge touches the plywood.*

NOTE For lampholders different from the cylindrical shape, the condition of the axis parallel to the plywood sheet may be obtained by adequate pine wood shimmings.

b) *Height of fall:*

*The striking element shall fall from one of the heights given in table 10.*

**Table 10 – Heights of fall**

<b>Material</b>	<b>Height of fall mm</b>
Ceramic parts	100 ± 1
Parts made of other material	150 ± 1,5

*Candle lampholders, if tested without decorative covers, shall, however, be tested with a height of fall of 100 mm.*

c) *Number of impacts:*

*Four blows shall be applied to points equally divided over the circumference of the outer edge of the shell and of the ring.*

*For lampholders of insulating material, the outer shell shall be hit at the outer edge. For metal lampholders, the outer shell shall be hit at the position of the insulating ring between the screw shell and the exterior.*

*For such candle lampholders as prescribed in b), one blow shall be applied in two places at 90° on the circumference. The blows shall be applied at 5 mm from the outer edge of the lampholder.*

d) *Pre-conditioning:*

*Not applicable.*

e) *Initial measurements:*

*Not applicable.*

f) *Attitudes and impact locations:*

*See c) above.*

g) *Operating mode and functional monitoring:*

*The sample shall not operate during impact.*

h) *Acceptance and rejection criteria:*

*After the test, the sample shall show no serious damage within the meaning of this standard, in particular*

1) *live parts shall not have become accessible.*

*Damage to the lampholder which does not reduce creepage distances or clearances below the values specified in clause 17 and small chips which do not adversely affect the protection against electric shock or ingress of water shall be ignored;*

2) *cracks not visible to the naked eye and surface cracks in fibre-reinforced mouldings and the like shall be ignored.*

*Cracks or holes in the outer surface of any part of the lampholder shall be ignored if the lampholder complies with this standard even if that part is omitted.*

i) *Recovery:*

*Not applicable.*

j) *Final measurements:*

*See h) above.*

*The mechanical strength of lampholders E5 and E10 shall be checked by means of the free fall test specified in IEC 60068-2-75.*

*The lampholder E5 or E10 shall withstand, without damage affecting safety, 50 falls of 500 mm onto a 3 mm thick steel plate in the tumbling barrel turning at 5 rev/min (that is 10 falls per minute).*

NOTE The mechanical strength of lampholders used in luminaires or other equipment may be checked by means of the spring hammer specified in IEC 60068-2-75. In IEC 60598-1, the test impact energy used varies from 0,2 Nm to 0,7 Nm depending on component material and luminaire type.

**15.6.1** Additionally, for lampholders provided with a snap-on outer shell the following tests are carried out.

*A push and a pull force along the lampholder axis is applied for 1 min. to the outer shell by means of a mass of 5 kg.*

*After this test the outer shell shall have remained in its intended position.*

*Additionally it shall not be possible to remove the outer shell by use of the standard finger tip, applied in all possible positions, with a force of 30 N.*

**15.7** *For metal lampholders the mechanical strength of external metal parts (outer shell and dome) is tested by means of an apparatus according to figure 9.*

*The various parts are tested on the complete lampholder. Each part is subjected twice for 1 min to a pressure as indicated in the table below, the pressure is applied on two diameters at right angles to each other. The test is not made on outer shells and domes of insulating material with a conductive outer surface.*

*During and after the test, the deformation of the specimen shall not exceed the values indicated in table 11.*

Table 11 – Maximum deformation values

Lampholder	Pressure N	Maximum deformation	
		During the test mm	After the test mm
E14	75	1	0,3
E27	100	2	0,3
E40	100	4	0,5

This test does not apply to lampholders E5 and E10 and similar small lampholders.

**15.8** Entry spouts and glands shall withstand the mechanical stresses occurring during normal fitting and use.

*Compliance is checked by the following test.*

*Screwed glands are fitted with a cylindrical metal rod having a diameter equal to the nearest whole number of millimetres below the internal diameter of the packing. The glands are then tightened by means of a suitable spanner, a force of 30 N for metal glands, or 20 N for glands of moulded material, being applied for 1 min, at a radius of 25 cm.*

*At the end of the test, the glands, the spouts and the enclosures shall show no damage.*

**15.9** Backplate lampholders shall be designed to withstand fixing to a support without damage.

*Compliance is checked by the following test.*

*The backplate of the lampholder is fixed by means of 4 mm screws to a rigid flat steel sheet. This sheet has two drilled and tapped holes at a distance equal to the distance between the axes of the fixing holes of the backplate. The screws are gradually tightened, the maximum torque applied being 1,2 Nm.*

*The backplate of lampholders shall be fixed by means of screws to a rigid flat steel sheet as follows:*

- 3 mm screws for lampholders E10;*
- 4 mm screws for lampholders other than E10.*

*The screws shall be gradually tightened, the maximum torque applied being:*

- 0,5 Nm for 3 mm screws, and*
- 1,2 Nm for 4 mm screws.*

*These requirements do not apply to lampholders E5.*

*For backplate lampholders specifically intended for building-in, this test is carried out with the means of attachment specified by the manufacturer.*

*After this test, the backplate lampholder shall show no damage impairing its further use.*

## **16 Screws, current-carrying parts and connections**

**16.1** Screws and mechanical connections, the failure of which might cause the holder to become unsafe, shall withstand the mechanical stresses occurring in normal use.

*Compliance is checked by inspection and by the following test.*

NOTE Screwed connections are already partially checked by the tests of clause 15.

*Screws and nuts which may be operated when connections are made to the lampholders are tightened and loosened*

- five times for screws operating in a female thread in metal;*
- ten times for screws operating in a female thread in insulating material*

by means of a suitable test screwdriver applying a torque as indicated in the table 12 below, except for set-screws tightened with an increased torque during the test of 15.4 when the increased torque is applied. Column 1 applies to screws without heads if the screw, when tightened, does not protrude from the hole. Column 2 applies to other screws. Screws operating in a female thread in insulating material are each time completely removed and reinserted.

*The test shall cause no damage impairing the further use of the screwed connections.*

**Table 12 – Torque values**

Nominal diameter of screw mm	Torque Nm	
	1	2
Up to and including 2,8	0,2	0,4
Over 2,8 up to and including 3,0	0,25	0,5
Over 3,0 up to and including 3,2	0,3	0,6
Over 3,2 up to and including 3,6	0,4	0,8
Over 3,6 up to and including 4,1	0,7	1,2
Over 4,1 up to and including 4,7	0,8	1,8
Over 4,7 up to and including 5,3	0,8	2,0
Over 5,3 up to and including 6,0	–	2,5
Over 6,0 up to and including 8,0	–	8,0
Over 8,0 up to and including 10,0	–	17,0
Over 10,0 up to and including 12,0	–	29,0
Over 12,0 up to and including 14,0	–	48,0
Over 14,0 up to and including 16,0	–	114,0

NOTE Screws to be operated when connections are made to the holder include, for example, screws for fixing covers when they have to be loosened for making connections, etc. Conduit thread connections and screws to fasten the holders to their supports are excluded.

*The shape of the blade of the test screwdriver shall suit the slot of the screw to be tested. The screw shall not be tightened in jerks.*

**16.2** In the case of screws operating in a thread in insulating material, the length of the thread shall be not less than 3 mm plus one-third of the nominal screw diameter, except that this length need not exceed 8 mm.

Correct introduction of the screw into the thread shall be ensured.

*Compliance is checked by inspection, by measurement and by a manual test.*

NOTE The requirement with regard to the correct introduction is met if introduction of the screw in a slanting manner is prevented, for example by guiding the screw by the part to be fixed, by a recess in the female thread or by the use of a screw with the leading thread removed.

**16.3** Electrical connections shall be so designed that contact pressure is not transmitted through insulating material other than ceramic, unless there is sufficient resiliency in the metal parts to compensate for any possible shrinkage of the insulating material.

Screws shall not be of a metal which is soft or liable to creep, such as zinc or aluminium.

Screws transmitting contact pressure and screws with a nominal diameter of less than 3 mm which may be operated when connections are made to the lampholder, shall screw into a metal nut or metal insert; locking screws are excepted from this requirement.

*Compliance is checked by inspection.*

**16.4** Screws and rivets, which serve as electrical as well as mechanical connections, shall be locked against loosening.

*Compliance is checked by inspection and by a manual test.*

NOTE 1 Spring washers may provide satisfactory locking. For rivets, a non-circular shank or an appropriate notch may be sufficient for locking.

NOTE 2 Sealing compound which softens on heating provides satisfactory locking only for screw connections not subject to torsion during normal use.

**16.5** Current-carrying parts shall be of copper, an alloy containing at least 50 % copper or material having characteristics at least equivalent.

This requirement does not apply to screws which do not essentially contribute to the current conduction such as terminal screws.

*Compliance is checked by inspection and, if necessary, by chemical analysis.*

*The tests of clauses 18 and 21 will show whether current-carrying parts are equivalent to copper in respect to current-carrying capacity, mechanical strength and corrosion likely to be met in normal service.*

NOTE Special care should be taken with regard to corrosion and mechanical properties.

## **17 Creepage distances and clearances**

**17.1** Creepage distances and clearances shall be not less than the values shown in the following tables 13a and 13b, the lampholder being fitted as in normal use and a lamp being inserted into or removed from the lampholder.

The central contact of the lamp cap shall have a diameter of

- 2,4 mm for lampholders E5;
- 3,8 mm for lampholders E10;
- 5,5 mm for lampholders E14;
- 10,5 mm for lampholders E27;
- 16,0 mm for lampholders E40.

The movement of any floating part shall be so limited as to prevent a decrease of creepage distances or clearances below the specified values.

NOTE 1 The distances specified in table 13a apply to impulse withstand category II, the distances specified in table 13b apply to impulse withstand category III in accordance to IEC 60664-1 and both tables refer to pollution degree 2, where normally only non-conductive pollution occurs but occasionally a temporary

conductivity caused by condensation must be expected. For information on distances for other impulse withstand categories or higher pollution degrees IEC 60664-1 should be consulted.

NOTE 2 Attention is drawn to the fact that the values for creepage distance and clearance given in this clause are the absolute minimum.

NOTE 3 The voltages shown in tables 13a and 13b are rated voltages, not ignition voltages.

**Table 13a – Minimum distances for a.c. (50/60 Hz) sinusoidal voltages  
Impulse withstand category II**

Distances mm	Rated voltage V			
	50	150	250	500 <sup>4)</sup>
1 Between live parts of different polarity, and 2 Between live parts and external metal parts, if not covered with insulating material: (this includes screws of backplate lampholders)  - Creepage distances insulation PTI $\geq$ 600 <sup>1)</sup> PTI < 600 <sup>1)</sup>  - Clearances <sup>4)</sup>	0,6 1,2 0,2	0,8 1,6 0,8	1,5 2,5 1,5	3 5 3
3 Clearances for backplate lampholders *)  - between live parts of different polarity, and  - between live parts and the boundary of the space for the supply wires in backplate lampholders not specifically intended for building in:	0,6	0,8	1,5	3
NOTE Values for creepage distances and clearances may be found for intermediate values of rated voltages by linear interpolation between tabulated values. No values are specified for rated voltages below 25 V as the voltage test of 14.4 is considered sufficient.				
*) These values take account of possible unevenness of the mounting surface.				

**Table 13b – Minimum distances for a.c. (50/60 Hz) sinusoidal voltages  
Impulse withstand category III**

Distances mm	Rated voltage V			
	50	150	250	500 <sup>4)</sup>
1 Creepage distances and clearances between live parts of different polarity 2 Between live parts and external metal parts, if not covered with insulating material: (this includes screws of backplate lampholders)  - Creepage distances insulation PTI $\geq$ 600 <sup>1)</sup> PTI < 600 <sup>1)</sup>  - Clearances <sup>4)</sup>	0,6 0,6 1,2 0,2	0,8 1,5 1,6 1,5	1,5 3 3 3	3 4 5 4
3 Clearances for backplate lampholders *)  - between live parts of different polarity, and  - between live parts and the boundary of the space for the supply wires in backplate lampholders not specifically intended for building in:	0,6	1,5	3	4
NOTE Values for creepage distances and clearances may be found for intermediate values of rated voltages by linear interpolation between tabulated values. No values are specified for rated voltages below 25 V as the voltage test of 14.4 is considered sufficient.				
*) These values take account of possible unevenness of the mounting surface.				

NOTE Information on standard ratings for specific holder types is given in clause 5.

- 1) *PTI (Proof Tracking Index) in accordance with IEC 60112.*
- 2) *In the case of creepage distances to parts not energized or not intended to be earthed, where no tracking can occur, the values specified for material with  $PTI \geq 600$  apply for all materials (in spite of the real PTI).*  
*For creepage distances subjected to working voltages of less than 60 s duration, the values specified for materials with  $PTI \geq 600$  apply for all materials.*
- 3) *For creepage distances not liable to contamination by dust or moisture, the values specified for material with  $PTI \geq 600$  apply (independent of the real PTI).*
- 4) *Clearances between live parts and a non-live screw shell in an empty lampholder (unscrewed lamp) shall not be less than 2 mm.*

NOTE Metal locking devices (see 9.3) for the coupling between outer shell and dome are considered as follows:

- if the locking device forms part of the centre contact, the clearances in item 1) apply;
- if the locking device forms part of the side contact(s), item 4) applies;
- if the locking device is a separate part, it shall only be taken into account in so far as it shortens any other required distance.

**Table 14 – Minimum distances for non-sinusoidal pulse voltages**

Rated pulse voltage (peak kV)	2	2,5	3	4	5	6	8
Minimum clearance (mm)	1	1,5	2	3	4	5,5	8

For distances subjected to both sinusoidal voltages and non-sinusoidal pulse voltages, the minimum required distance shall not be less than the highest value indicated in either table.

Creepage distances shall be not less than the required minimum clearance.

Minimum creepage distances and clearances between live parts of different polarity shall be reduced to 1 mm for lampholders E5 and to 2 mm (for  $PTI < 600$ ) for lampholders E10 intended for series connected lamps (maximum rated voltage 25 V for lampholders E5 and 60 V for lampholders E10).

*Compliance is checked by measuring with and without supply wires of the largest cross-sectional area according to 10.1 connected to the terminals.*

**17.2** Sealing compound shall not protrude above the edge of the cavity.

*Compliance is checked by inspection.*

## 18 Normal operation

Normal use shall cause no excessive wear or other harmful effect.

Insulation and protection against accidental contact shall not be seriously affected. Linings, barriers and the like shall have adequate mechanical strength and shall be reliably fixed.

Temperature rise and vibration to be expected in normal use shall not cause loosening of electrical connections.

*Compliance is checked by the following test.*

*The specimen shall be placed in a test apparatus as shown in figure 4. A corresponding test cap, according to figure 5 shall be screwed in and out 100 times at a rate of about 15 times per minute.*

*The lampholder shall be fixed during half the number of operations by the threaded entry, dome or backplate according to the type of lampholder, and during the other half clamped at the outer shell.*

*The test cap is screwed in with a torque of*

- 0,4 Nm for candle lampholders E14;*
- 1 Nm for lampholders E14;*
- 1,5 Nm for lampholders E27;*
- 3 Nm for lampholders E40.*

*At the end of the test, the specimen shall show*

- no wear impairing its operation;*
- no damage impairing protection against electric shock;*
- no loosening of electrical contacts;*
- no loosening of the connection between shell and dome;*
- no loosening of the set screw locking the threaded entry.*

*Finally the specimen shall comply with the requirements of 8.2 and shall withstand an electric strength test according to 14.4, the test voltage being 500 V lower in each case.*

NOTE The moisture treatment of clause 14 is not repeated before this voltage test.

These requirements do not apply to lampholders E5 and E10.

## **19 General resistance to heat**

**19.1** Lampholders shall be sufficiently resistant to heat.

*Compliance is checked by the tests of 19.2 to 19.4.*

### **19.2**

- For E27 lampholders*

*The lampholder is first checked by means of the gauges according to the current edition of standard sheets 7006-22C and 7006-22D of IEC 60061-3.*

*After these tests, a solid steel (preferably stainless steel) test cap, complying with figure 14 is screwed into the lampholder, mounted according to its intended use, with a torque of 1,5 Nm. The lampholder, with the test cap screwed in, is then placed in a vertical holder-up position (because the weight of the test cap shall not bear on the holder), in a heating cabinet having a temperature of approximately 85 °C.*

*This temperature is raised to 175 °C within 1 h ± 15 min. For lampholders which form an integral part of the luminaire, this temperature is replaced by that one measured according to the operating conditions given in 12.4.2 of IEC 60598-1, plus 10 K, with a tolerance of ±5 °C.*

*After reaching and maintaining this temperature the lampholder is loaded for 48 h with a current equal to the rated current of the lampholder.*

*After this period, the lampholder is removed from the heating cabinet and allowed to cool down for 24 h without the test cap.*

*The tests with gauges 7006-22C and 7006-22D are then repeated.*

*The lampholder shall still comply with these gauges.*

– *For E14 lampholders*

*A solid steel (preferably stainless steel) test cap B, complying with figure 13 is screwed into a candle lampholder E14, mounted according to its intended use, with a torque of 0,4 Nm and into all other lampholders E14 with a torque of 1 Nm. The lampholder, with test cap B screwed in, is then placed in a vertical holder up position (because the weight of the test cap shall not bear on the holder), in a heating cabinet having a temperature of approximately 70 °C. This temperature is raised to 145 °C within 1 h ± 15 min. For lampholders which form an integral part of the luminaire, this temperature is replaced by that one measured according to the operating conditions given in 12.4.2 of IEC 60598-1, plus 10 K, with a tolerance of ±5 °C.*

*After reaching and maintaining this temperature the lampholder is loaded for 48 h with a current equal to the rated current of the lampholder.*

*After this period, the lampholder is removed from the heating cabinet and allowed to cool down for 24 h without the test cap.*

*A solid brass cap A complying with figure 13 is then screwed into the lampholder with the same torque and then unscrewed. This sequence of operations is performed 10 times, after which the contact resistance between the terminals of the lampholder is measured.*

*This measurement is made at the rated current of the lampholder, in an a.c. circuit of not more than 6 V; for switched lampholders the contact resistance in the switch is neglected. The measured contact resistance shall not exceed 0,02 Ω.*

NOTE Test cap A is carefully cleaned and polished before being screwed into the lampholder for the contact resistance measurement.

– *For E27 and E14 lampholders*

*T-marked lampholders shall be tested at the marked temperature plus 10 °C.*

*Lampholders intended for use in refrigerators and food freezers shall be tested at the upper value of the rated operating temperature plus 10 °C.*

NOTE The value of 10 °C is being studied and is temporarily kept in line with the present requirements for E27 lampholders.

*These requirements do not apply to lampholders E5, E10 and E40.*

**19.3** Contacts and all other current-carrying parts shall be so constructed as to prevent excessive temperature rise.

*Compliance is checked by the following test which shall be made immediately after the test of 19.2 on the lampholder in whose terminals conductors of the maximum cross-sectional area according to 10.1 are fitted.*

*The terminal screws are tightened with a torque equal to two-thirds of the torque specified in 16.1; the lampholder is placed with the open end downwards and loaded for 1 h with 1,25 times its rated current.*

*The temperature rise of terminals shall not exceed 45 K.*

*This temperature is determined with the aid of melting particles or by thermocouples, not by means of thermometers.*

*For this test, a special test cap shown in figure 11 is used.*

*After the test, it is verified that, as required in 10.4, the conductors are not damaged.*

NOTE Pellets of beeswax (diameter 3 mm, melting temperature 65 °C) may be used as melting particles provided that the ambient temperature equals 20 °C.

These requirements do not apply to lampholders E5 and E10 with a rated voltage not exceeding 60 V.

**19.4** The resistance to heat is then tested in a heating cabinet at the temperature indicated in the table 15.

**Table 15 – Heating cabinet temperatures**

<b>Lampholder</b>	<b>Temperature °C</b>
E10 general	75
E5 and E10 integral part of luminaire*	75 or measured temperature + 15 (whichever is the highest)
E14	170
E27	200
E40	260
* For E5, E10 and similar small lampholders which form an integral part with the luminaire such as Christmas tree lighting chains, the temperature is measured in the luminaire on the lamp cap at a distance of 2 mm from the lamp glass-to-cap junction.	

*T-marked lampholders are tested at the marked temperature plus 35 K.*

*Lampholders intended for use in refrigerators and food freezers are tested:*

- a) at the rated minimum temperature, and*
- b) at the rated operating temperature plus 35 K.*

*In case of a) the duration of the test shall be reduced to 16 h.*

*Immediately after this test, the lampholders shall once more be subjected to the test of 15.6.*

*A solid steel (preferably stainless steel) test cap, complying with figure 13 (test cap B), 14 or 15 is screwed fully home in the lampholder. The lampholder with the test cap screwed in is then placed in a vertical holder-up position (because the weight of the test cap shall not bear on the holder), in a heating cabinet having approximately half the temperature specified in the table. This temperature is raised to the required*

*test temperature within 1 h  $\pm$  15 min. Following this, the test is continued for 168 h without interruption.*

*The test temperature is maintained with a tolerance of  $\pm 5$  K.*

*During the test, the lampholder shall not undergo any change impairing its further use especially in the following respects*

- reduction of the protection against electric shock;
- loosening of electrical contacts;
- cracks, swelling or shrinking;
- sealing compound flowing out.

*The test cap is removed from the lampholder after cooling down to approximate room temperature.*

*At the end of the test, it is checked if the Edison threads are not deformed. The test is made by means of the "Go" gauges shown in the current edition of standard sheets 7006-25 or 7006-25A of IEC 60061-3, as appropriate.*

*In addition, the holder shall withstand the mechanical strength tests made under the conditions specified in 15.2 and 15.6, the torque, however, being reduced to 50 % of the original value and the height of fall being reduced to 5 cm, respectively.*

*Sealing compound shall not flow to such an extent that live parts are exposed; a mere displacement of the compound is neglected.*

This test is not made on integral lampholders.

## **20 Resistance to heat, fire and tracking**

**20.1** Parts retaining the contacts and external parts of lampholders of insulating material and of lampholders comprising external parts of insulating material with a conductive outer surface shall be resistant to heat.

*For material other than ceramic compliance is checked with the aid of the ball-pressure test by means of the apparatus shown in figure 10.*

*All the tests required by clause 20 of this standard are not performed on lampholders which are integral with a luminaire, as similar tests are required in section 13 of IEC 60598-1. However, the operating conditions of these tests will take into account the ones specific to lampholders and defined in clause 20 of this standard.*

*For lampholders E5 and E10, only the parts retaining the contacts are subjected to the ball-pressure test.*

*The surface of the part under test is placed in the horizontal position and a steel ball of 5 mm diameter is pressed against this surface with a force of 20 N.*

*The test is made in a heating cabinet at a temperature shown in 19.4, except for lampholders E5 and E10, where the temperature is 125 °C.*

*The test load and the supporting means are placed in the heating cabinet for a sufficient time to ensure that they have attained the stabilized testing temperature before the test commences.*

*The part to be tested is placed in the heating cabinet for a period of 1 h, before the test load is applied.*

*If the surface under test bends, the part where the ball presses is supported. For this purpose, if the test cannot be made on the complete specimen, a suitable part may be cut from it.*

*The specimen shall be at least 2,5 mm thick, but if such a thickness is not available on the specimen then two or more pieces are placed together.*

*After 1 h, the ball is removed from the specimen which is then immersed within 10 s in cold water for cooling down to approximately room temperature. The diameter of the impression caused by the ball is measured and shall not exceed 2 mm.*

NOTE In the event of curved surfaces, such as lampholder shells, the shorter axis is measured if the indent is elliptical.

In case of doubt, the depth of the impression is measured and the diameter  $\phi$  calculated using the formula:  $\phi = 2\sqrt{p(5-p)}$ , in which  $p$  = depth of impression.

**20.2** External parts of insulating material (outer shell, screw shell, dome or backplate) providing protection against electric shock, and parts of insulating material (terminal/contact assembly) retaining live parts or ELV parts in position, shall be resistant to flame and ignition.

*For materials other than ceramic, compliance is checked by the test of 20.3 or 20.4.*

Screw shells which are only live when a lamp is inserted into the lampholder are not deemed to be live parts within the meaning of this requirement.

Insulating material retaining such shells in place is therefore checked by the test of 20.3.

**20.3** External parts of insulating material, including those with a conductive exterior, providing protection against electric shock, and parts of insulating material retaining ELV parts in position, are subjected to the glow-wire test in accordance with IEC 60695-2-11, subject to the following details.

- *The specimen is a complete holder. It may be necessary to take away parts of the holder to perform the test, but care should be taken to ensure that the test conditions are not significantly different from those occurring in normal use.*
- *The specimen is mounted on the carriage and pressed against the glow-wire tip with a force of 1 N, preferably 15 mm, or more, from the upper edge, into the centre of the surface to be tested. The penetration of the glow-wire into the specimen is mechanically limited to 7 mm.*

*If it is not possible to make the test on a specimen as described above because the specimen is too small, the above test is made on a separate specimen of the same material,*

*30 mm × 30 mm square and with a thickness equal to the smallest thickness of the specimen.*

- *The temperature of the tip of the glow-wire is 650 °C.*

*After 30 s the specimen is withdrawn from contact with the glow-wire tip. The glow-wire temperature and heating current are constant for 1 min prior to commencing the test. Care should be taken to ensure that heat radiation does not influence the specimen during this period. The glow-wire tip temperature is measured by means of a sheathed fine wire thermocouple constructed and calibrated as described in IEC 60695-2-11.*

- *Any flame or glowing of the specimen shall extinguish within 30 s of withdrawing the glow-wire and any flaming drops of the material shall not ignite a piece of tissue paper, as specified in definition 4.187 of ISO 4046-4, spread out horizontally 200 mm ± 5 mm below the specimen.*

**20.4** Parts of insulating material retaining live parts or ELV lamp contacts in position, are subjected to the needle-flame test in accordance with IEC 60695-11-5, subject to the following details.

- *The specimen is a complete lampholder. It may be necessary to take away parts of the lampholder to perform the test, (for example contacts, which would otherwise shield the area to be tested), but care should be taken to ensure that the test conditions are not significantly different from those occurring in normal use.*
- *The test flame is applied to the centre of the surface to be tested.*
- *The duration of application is 10 s.*
- *Any self-sustaining flame shall extinguish within 30 s of removal of the gas flame and any flaming drops of the material shall not ignite a piece of tissue paper, spread out horizontally 200 mm ± 5 mm below the specimen.*

NOTE For additional information see the explanatory sheet, figure 18.

**20.5** For drip-proof lampholders, insulating parts retaining live parts or ELV parts in position shall have adequate resistance to tracking.

*For materials other than ceramic, compliance shall be checked by the proof tracking test in accordance with IEC 60112, subject to the following details.*

- *If the specimen has no flat surface of at least 15 mm × 15 mm, the test may be carried out on a flat surface with reduced dimensions provided drops of liquid do not flow off the specimen during the test.*

*No artificial means should, however, be used to retain the liquid on the surface. In case of doubt, the test may be made on a separate strip of the same material, having the required dimensions and manufactured by the same process.*

- *If the thickness of the specimen is less than 3 mm, two, or if necessary, more, specimens should be stacked to obtain a thickness of at least 3 mm.*
- *The test shall be made at three places of the specimen or on three specimens.*
- *The electrodes shall be of platinum and test solution A, as described in subclause 7.3 of IEC 60112, shall be used.*
- *For drip-proof lampholders the specimen shall withstand 50 drops without failure at a test voltage of PTI 175.*
- *A failure has occurred if a current of 0,5 A or more flows for at least 2 s in a conducting path between the electrodes on the surface of the specimen, thus operating the overcurrent relay, or if the specimen burns without releasing the overcurrent relay.*
- *Clause 9 of IEC 60112 regarding determination of erosion, does not apply.*

## **21 Resistance to excessive residual stresses (season cracking) and to rusting**

**21.1** Contacts and other parts of rolled sheets of copper or copper alloy whose failure might cause the lampholder to become unsafe shall not be damaged due to excessive residual stresses.

*Compliance is checked by the following test.*

*The surface of the specimens is carefully cleaned, varnish being removed by acetone, and grease and finger prints by petroleum spirit or the like.*

*The specimens are placed for 24 h in a test cabinet, the bottom of which is covered by an ammonium chloride solution having a pH value of 10 (for details of the test cabinet, the test solution and the test procedure, see annex A).*

*After this treatment, the specimens are washed in running water; 24 h later they shall show no cracks when inspected at an optical magnification of 8 ×.*

*Cracks which may occur in very restricted areas of the outer shell of metal lampholders near the fixing areas of the insulating ring shall not be considered.*

NOTE In order not to influence the results of the test, the specimens should be handled with care.

**21.2** Ferrous parts, the rusting of which may endanger the safety of the lampholder, shall be adequately rust protected.

*Compliance is checked by the following test.*

*All grease is removed from parts to be tested by immersion in a suitable degreasing agent for 10 min. The parts are then immersed for 10 min in a water solution of 10 % ammonium chloride at a temperature of 20 °C ± 5 °C.*

*Without drying, but after shaking off drops of water, the parts are placed for 10 min in a box containing air saturated with moisture at a temperature of 20 °C ± 5 °C.*

*After the parts have been dried for 10 min in a heating cabinet at a temperature of 100 °C ± 5 °C, any traces of rust on sharp edges and any yellowish film may be removed by rubbing, after which their surface shall show no signs of rust.*

*For small helical springs and the like, and for ferrous parts exposed to abrasion, a layer of grease is deemed to provide sufficient rust protection.*

*Such parts are not subjected to the test.*

**Annex A**  
(normative)

**Season cracking/corrosion test**

NOTE In the interest of environmental protection, the following requirements relating to test solution, volume and volume of vessel may be modified at the discretion of the test laboratory.

In this event, the test vessel should retain a volume in the range 500 to 1 000 times larger than the volume of the sample and the volume of test solution should be such that the ratio of vessel volume to solution volume is in the range of 20:1 to 10:1. In case of doubt, however, the conditions of clause A.1 apply.

**A.1 Test cabinet**

*Closeable glass vessels shall be used for the test. These may, for example, be desiccator vessels or simple glass troughs with ground rim and lid. The vessels volume shall be at least 10 l.*

*A certain ratio of test space to volume of test solution shall be maintained (20:1 to 10:1).*

**A.2 Test solution**

*Preparation of 1 l of solution:*

*Dissolve 107 g ammonium chloride (reagent grade  $\text{NH}_4\text{Cl}$ ) in about 0,75 l of distilled or fully demineralized water and add as much of 30 % sodium hydroxide solution (prepared from reagent grade  $\text{NaOH}$  and distilled or fully demineralized water) as is necessary to reach a pH value of 10 at 22 °C. For other temperatures, adjust this solution to the corresponding pH values specified in table A.1.*

**Table A.1 – pH adjustment**

Temperature °C	Test solution pH
22 ± 1	10,0 ± 0,1
25 ± 1	9,9 ± 0,1
27 ± 1	9,8 ± 0,1
30 ± 1	9,7 ± 0,1

*After the pH adjustment, make up to 1 litre with distilled or fully demineralized water. This does not change the pH value any further.*

*Keep the temperature constant in any event to within ±1 °C during the pH adjustment, and carry out the pH measurement using an instrument which permits an adjustment of the pH value to within ±0,02.*

The test solutions may be used over a prolonged period, but the pH value, which represents a measure of the ammonia concentration in the vapour atmosphere, shall be checked at least every three weeks and adjusted if necessary.

### A.3 Test procedure

*Introduce, preferably suspended, the specimens in the test cabinet in such a way that the ammonia vapour can take effect unhindered. The specimens shall not dip into the test solution nor touch each other. Supports or suspension devices shall be made of materials which are not susceptible to attack by ammonia vapour, e.g. glass or porcelain.*

*Testing shall be carried out at a constant temperature of  $(30 \pm 1)$  °C to exclude visible condensed water formation caused by temperature fluctuations, which could severely falsify the test result.*

*Prior to testing, the test cabinet containing the test solution shall be brought to a temperature of  $(30 \pm 1)$  °C. The test cabinet shall subsequently be filled as quickly as possible with the specimens pre-heated to 30 °C and closed.*

*This moment is to be considered the beginning of the test.*

**Annex B**  
(informative)

**Guidance for requirements in IEC 61058-1 applicable to switches  
in lampholders (see 13.2)**

The clauses and subclauses refer to IEC 61058-1

## **6 Rating**

Subclauses 6.1 and 6.3 are applicable with the following limitations:

6.1 The maximum rated voltage is 250V.

6.3 The maximum rated current is 2A.

### **7.1 Classification of switches**

#### **7.1.1 According to nature of supply**

Only 7.1.1.1 is applicable.

#### **7.1.2 According to type of load to be controlled by each circuit of the switch**

Only 7.1.2.4, 7.1.2.7 and 7.1.2.8 are applicable.

#### **7.1.3 According to ambient temperature**

Only 7.1.3.2 is applicable.

#### **7.1.4 According to number of operating cycles**

Only 7.1.4.3 is applicable.

For switched lampholders intended to be used in refrigerators or food freezers, 7.1.4.2 applies if the switch is actuated by the door of the refrigerator or food freezer.

#### **7.1.9 According to application level for resistance to heat and fire**

Only 7.1.9.1 is applicable.

## **8 Marking and documentation**

Not applicable; 13.3 of IEC 60238 applies.

## **16 Heating**

### **16.1 General requirements**

Switches in lampholders intended to be used in refrigerators or food freezers are tested at the rated operating temperatures.

**20.2 Creepage distances**

Material group IIIb is not useable.

For switched lampholders intended to be used in refrigerators or food freezers, Note 5 is applicable.

**Annex C**  
(informative)

**Guidance for special requirements in appliance standards –  
Household and similar electrical appliances**

NOTE – This standard is based on the requirements of the IEC 60598 series for luminaires. For application in other appliances (e.g. household appliances) the requirements of the relevant appliance standard should be observed.

**C.1 List of relevant standards**

The following list contains references to appliance standards in which experience has shown that lampholders covered by this standard may be built-in. This list shows a selection of the existing standards and does not lay claim to be exhaustive.

Publication	Title
IEC 60335-1	Household and similar electrical appliances – Safety – Part 1: General requirements
IEC 60335-2-6	Household and similar electrical appliances – Safety – Part 2-6: Particular requirements for stationary cooking ranges, hobs, ovens and similar appliances
IEC 60335-2-9	Household and similar electrical appliances – Safety – Part 2-9: Particular requirements for grills, toasters and similar portable cooking appliances
IEC 60335-2-11	Household and similar electrical appliances – Safety – Part 2-11: Particular requirements for tumble dryers
IEC 60335-2-24	Household and similar electrical appliances – Safety – Part 2-24: Particular requirements for refrigerating appliances, ice-cream appliances and ice-makers
IEC 60335-2-25	Household and similar electrical appliances – Safety – Part 2-25: Particular requirements for microwave ovens, including combination microwave ovens
IEC 60335-2-27	Household and similar electrical appliances – Safety – Part 2-27: Particular requirements for appliances for skin exposure to ultraviolet and infrared radiation
IEC 60335-2-31	Household and similar electrical appliances – Safety – Part 2-31: Particular requirements for range hoods
IEC 60335-2-36	Household and similar electrical appliances – Safety – Part 2-36: Particular requirements for commercial electric cooking ranges, ovens, hobs and hob elements
IEC 60335-2-42	Household and similar electrical appliances – Safety – Part 2-42: Particular requirements for commercial electric forced convection ovens, steam cookers and steam-convection ovens
IEC 60335-2-43	Household and similar electrical appliances – Safety – Part 2-43: Particular requirements for clothes dryers and towel rails

IEC 60335-2-49	Household and similar electrical appliances – Safety – Part 2-49: Particular requirements for commercial electric hot cupboards
IEC 60335-2-59	Household and similar electrical appliances – Safety – Part 2-59: Particular requirements for insect killers
IEC 60335-2-99	Household and similar electrical appliances – Safety – Part 2-99: Particular requirements for commercial electric hoods

**C.2 Reference to special requirements****IEC 60335-1:**

Clause 8 – Protection against access to live parts

Clause 11 – Heating

Table 3 – Maximum normal temperature rises

Clause 24 – Components

Subclauses 24.1, 24.1.3 and 24.1.6 apply

Clause 29 – Clearances, creepage distances and solid insulation

Requirements regarding resistance to tracking are given in 29.2.

Requirements regarding thickness of solid insulation are given in 29.3.

Clause 30 – Resistance to heat and fire

Annex E (normative) – Needle flame test

Annex H (normative) – Switches

Annex N (normative) – Proof tracking test

Annex O (informative) – Selection and sequence of the tests of clause 30

**IEC 60335-2-24: Particular requirements for refrigerating appliances, ice-cream appliances and ice-makers:**

Clause 7 – Marking and instructions

There is no special marking requirement for lampholders within clause 7 of IEC 60335-2-24. Nevertheless the following requirement is considered to be essential:

In case of lampholders intended for use in a refrigerated compartment of refrigerators and food freezers, the rated minimum temperature to which the lampholder can be subjected shall be marked on the lampholder. (e.g.  $-30\text{ }^{\circ}\text{C}$ )

Clause 8 – Protection against access to live parts

Clause 24 – Components

Particular requirements for switches in doors are given in 24.1.3

Clause 29 – Clearances, creepage distances and solid insulation

Requirements regarding resistance to tracking are given in 29.2:

For lampholders intended for use in a refrigerated compartment of refrigerators and food freezers, the specimen shall withstand 50 drops without failure at a test voltage of PTI 250.

Metric ISO thread

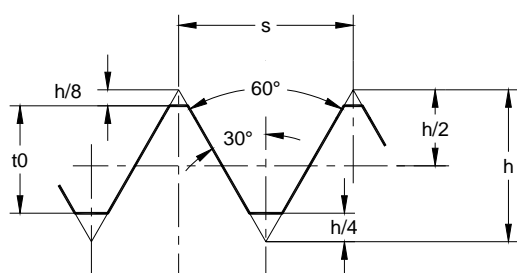

$$h = 0,866\ 03\ s$$

$$h/4 = 0,216\ 51\ s$$

$$h/8 = 0,108\ 25\ s$$

$$t_0 = 5/8h = 0,541\ 27\ s$$

IEC 1230/04

Basic profile\*

\* The basic profile is the profile to which the deviations defining the limits of the external and the internal threads are applied.

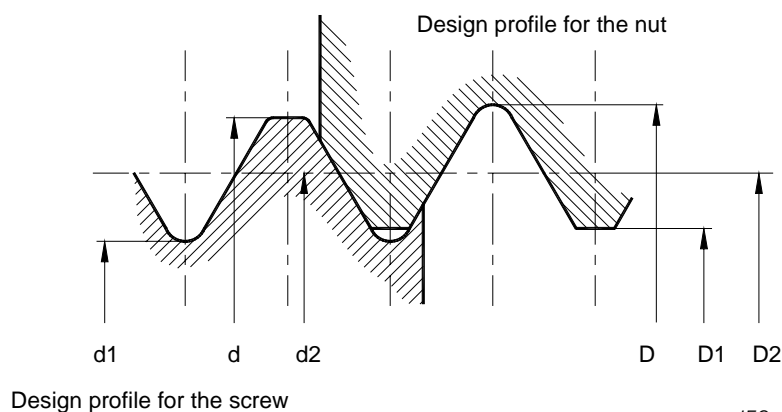

IEC 1231/04

Dimensions in millimetres

Designation	s	Screw					Nut				
		d		d2		d1	D	D2		D1	
		Max.	Min.	Max.	Min.	Max.	Min.	Max.	Min.	Max.	Min.
M8×1	1	8,000	7,800	7,350	7,238	7,917	8,000	7,462	7,350	7,117	6,917
M10×1	1	10,000	9,800	9,350	9,238	8,917	10,000	9,462	9,350	9,117	8,917
M13×1	1	13,000	12,800	12,350	12,190	11,917	13,000	12,510	12,350	12,117	11,917
M16×1	1	16,000	15,800	15,350	15,190	14,917	16,000	15,510	15,350	15,117	14,917

**Figure 1a – Nipple thread for lampholders.  
Basic profile and design profile for the nut and for the screw**

ISO standard pipe thread

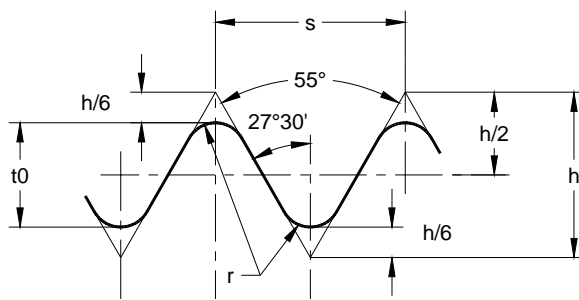

$$h = 0,960\ 491\ s$$

$$h/6 = 0,160\ 082\ s$$

$$t_0 = 2/3h = 0,640\ 327\ s$$

$$r = 0,137\ 329\ s$$

IEC 1232/04

Basic profile\*

\* The basic profile is the profile to which the deviations defining the limits of the external and the internal threads are applied.

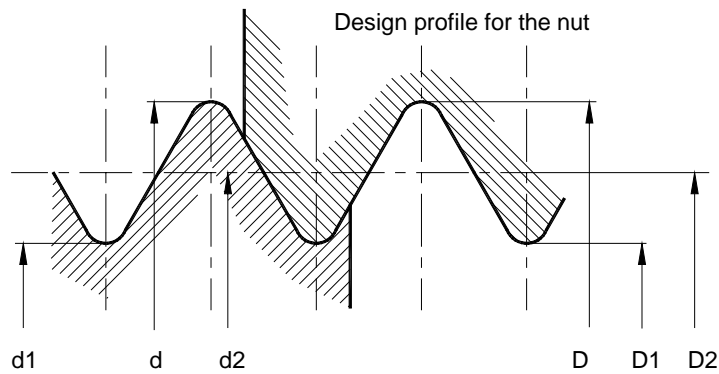

Design profile for the screw

IEC 1233/04

Dimensions in millimetres

Designation	n*	Screw					Nut				
		d		d2		d1	D	D2		D1	
		Max.	Min.	Max.	Min.	Max.	Min.	Max.	Min.	Max.	Min.
G3/8A	19	16,662	16,412	15,806	15,681	14,950	16,662	15,931	15,806	15,395	14,50

\* Number of threads per inch.

Figure 1b – Nipple thread for lampholders.  
Basic profile and design profile for the nut and for the screw

Gauges for the screw

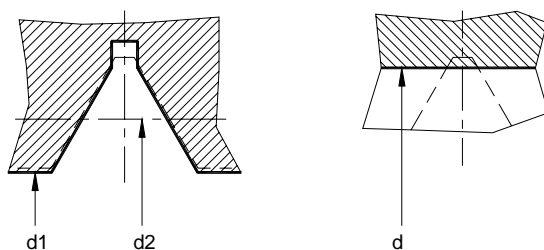

--- Basic profile (see figure 1a)

 "Go" gauge

 "Not Go" gauge

IEC 1234/04

Dimensions in millimetres

Designation	s	d		d2		d1		Wear
			Tolerance		Tolerance		Tolerance	
M10×1	1	9,800	+0,004	9,35	-0,012	8,91	+0,004	0,012
			-0,004	0	-0,020	7	-0,004	
M13×1	1	12,800	+0,004	12,3	-0,012	11,9	+0,004	0,012
			-0,004	50	-0,020	17	-0,004	
M16×1	1	15,800	+0,004	15,3	-0,012	14,9	+0,004	0,012
			-0,004	50	-0,020	17	-0,004	

Gauges for the nut

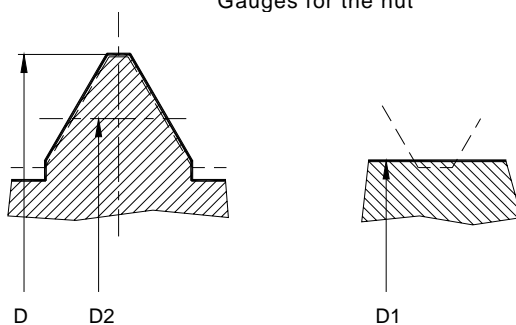

--- Basic profile (see figure 1a)

 "Go" gauge

 "Not Go" gauge

IEC 1235/04

Dimensions in millimetres

Designation	s	D		D2		D1		Wear
			Tolerance		Tolerance		Tolerance	
M10×1	1	10,000	+0,004	9,35	+0,012	9,11	+0,004	0,012
			-0,004	0	+0,020	7	-0,004	
M13×1	1	13,000	+0,004	12,3	+0,012	12,1	+0,004	0,012
			-0,004	50	+0,020	17	-0,004	
M16×1	1	16,000	+0,004	15,3	+0,012	15,1	+0,004	0,012
			-0,004	50	+0,020	17	-0,004	

**Figure 2a – Gauges for metric ISO thread for nipples**

Gauges for the screw

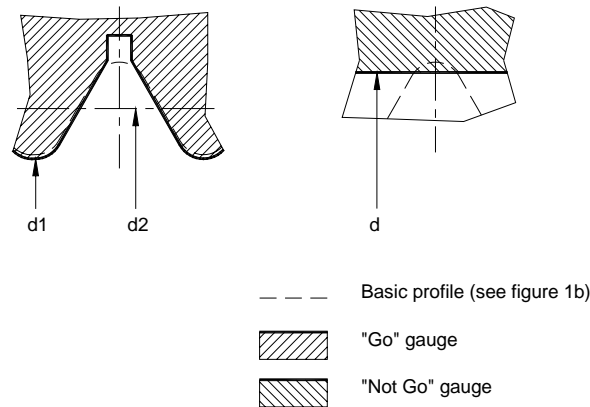

IEC 1236/04

Dimensions in millimetres

Designation	n*	d		d2		d1		Wear
			Tolerance		Tolerance		Tolerance	
G3/8A	19	16,412	+0 -0,008	15,806	+0 -0,020	14,950	+0 -0,018	-

\* Number of threads per inch

Gauges for the nut

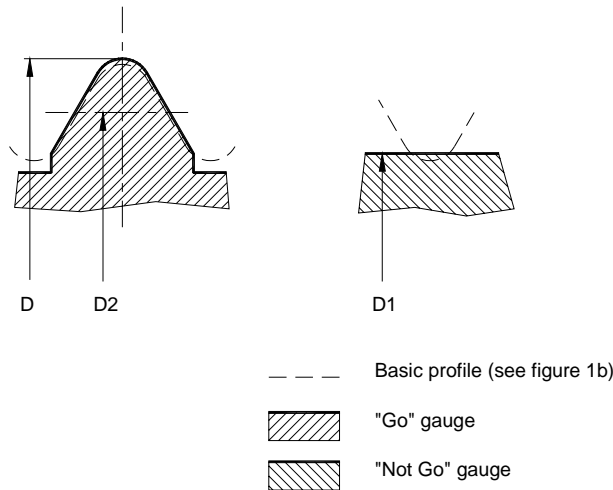

IEC 1237/04

Dimensions in millimetres

Designation	n*	D		D2		D1		Wear
			Tolerance		Tolerance		Tolerance	
G3/8A	19	16,662	+0,018 -0,005	15,806	+0,005 +0,028	15,395	+0,008 -0	0,005

\* Number of threads per inch.

Figure 2b – Gauges for ISO standard pipe thread for nipples

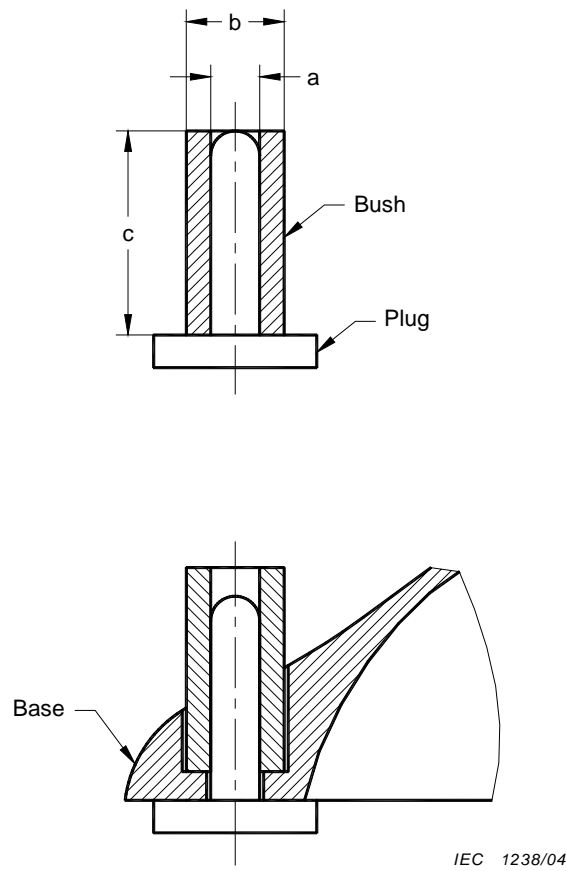

*Dimensions in millimetres*

Reference	Dimension	Tolerance	
		Manufacture	Wear
a	4,1	+0,03 -0,0	+0,0 -0,03
b	8,2	+0,03 -0,0	+0,0 -0,03
c	18	+0,1 -0,1	- -

**Figure 3 – Gauge for holes for backplate lampholder screws**

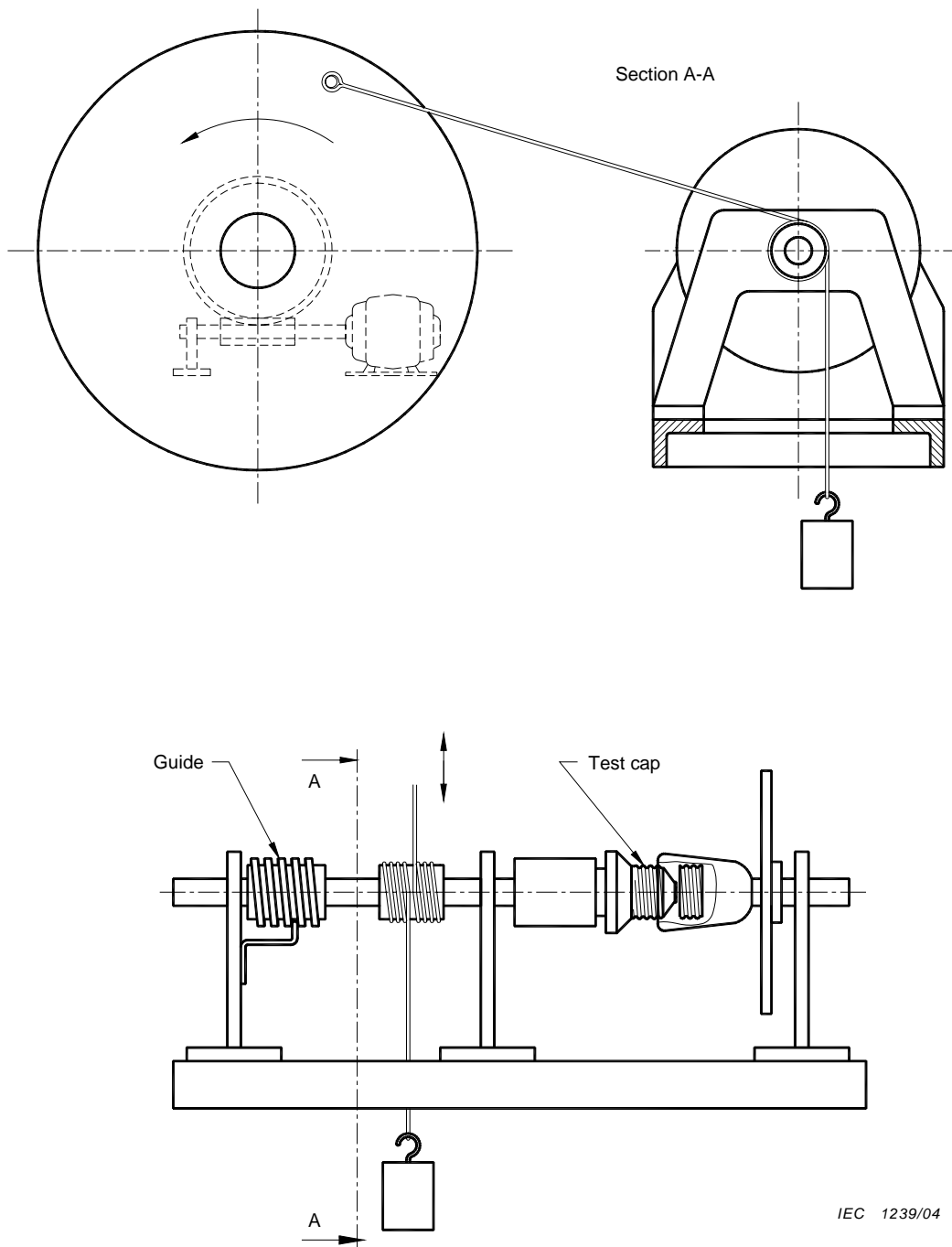
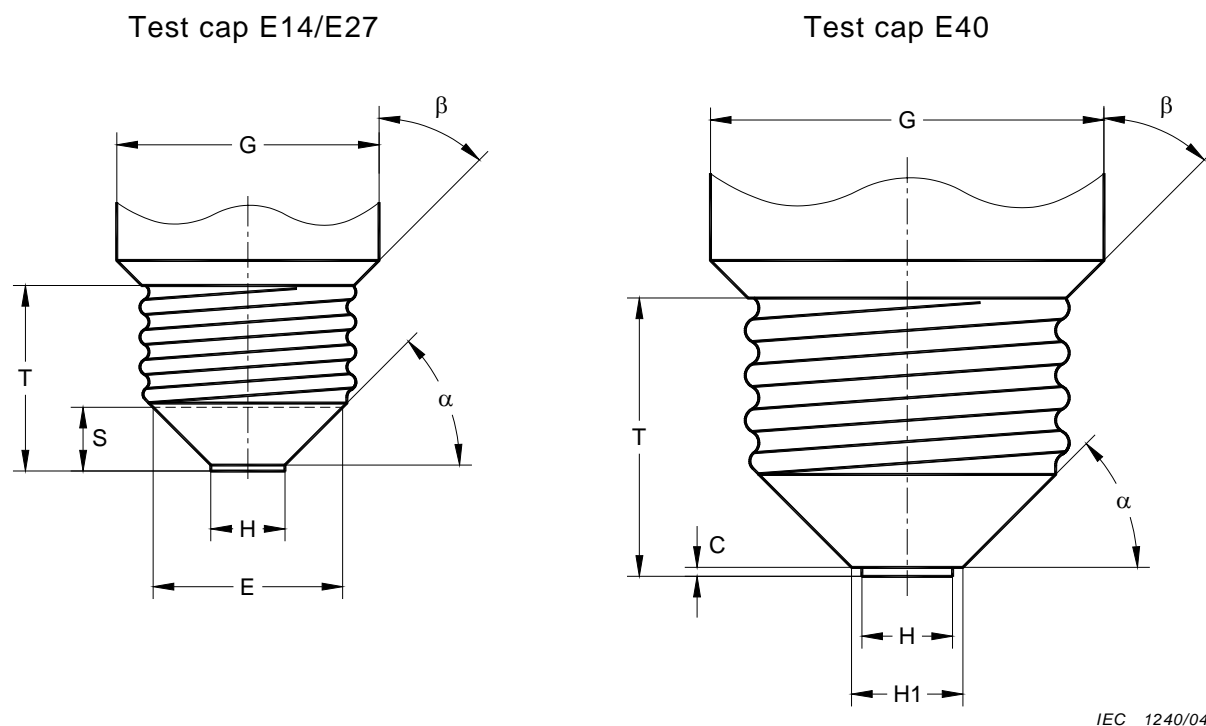

Figure 4 – Normal operation test apparatus



Material: Hardened steel

NOTE The dimensions of the thread on the test cap shall be between the maximum and minimum values specified for E14, E27 and E40 caps in standard sheets 7004-23, 7004-21 and 7004-24 of IEC 60061-1 respectively.

Dimensions in millimetres

Lampholder	C	E	G	H	H1	S	T	$\alpha$	$\beta$
E14	–	12	17	4,8	–	4	17	45°	45°
E27	–	23	32	9,5	–	7,7	23	45°	45°
E40	0,5	–	50	14	17	–	35	45°	45°
Tolerance	+0,1 –0,1	– –	+0,5 –0,5	+0,1 –0,1	+0,1 –0	+0,1 –0	+0,1 –0,1	+30′ –30′	+1° –1°

Figure 5 – Test caps for the test of clause 18

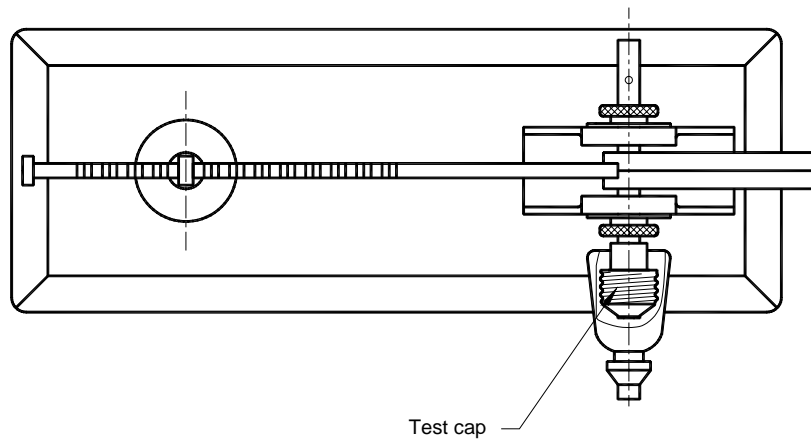
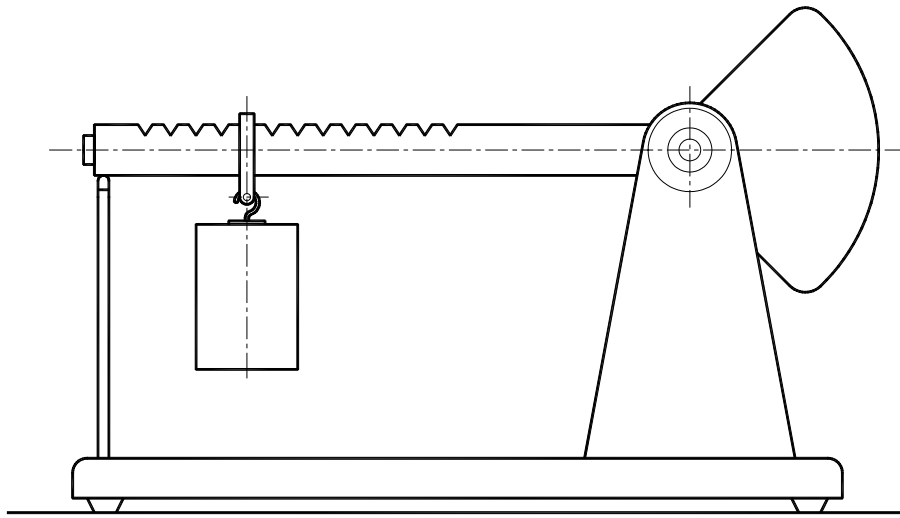

IEC 1241/04

Figure 6 – Torque apparatus

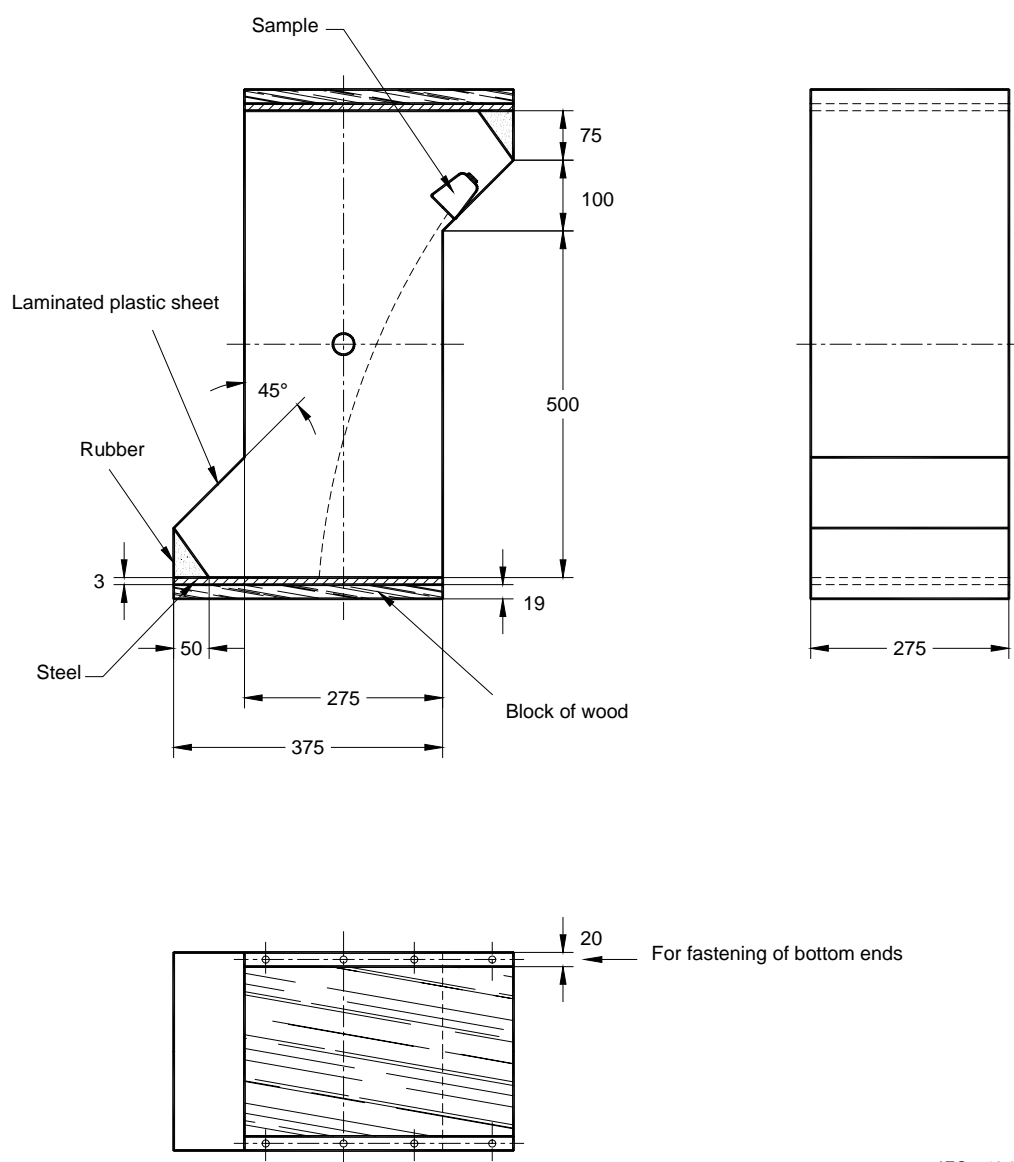

IEC 1242/04

The body of the tumbling barrel shall be made of steel sheet of 1,5 mm thickness.

The compartments where the sample rests between individual falls, shall be backed by a rubber part made of chip-resistant rubber with a hardness of 80 IRHD and the sliding surfaces of these parts shall be made of laminated plastic sheet, such as "Formica".

The tumbling barrel shall be provided with an aperture with lid made of transparent acrylic.

The shaft of the tumbling barrel shall not protrude into the barrel itself.

**Figure 7 – Tumbling barrel**

NOTE For information, this drawing has been retained in this standard, although there is a basic standard.

In case of doubt regarding the drawing, refer to IEC 60068-2-75.

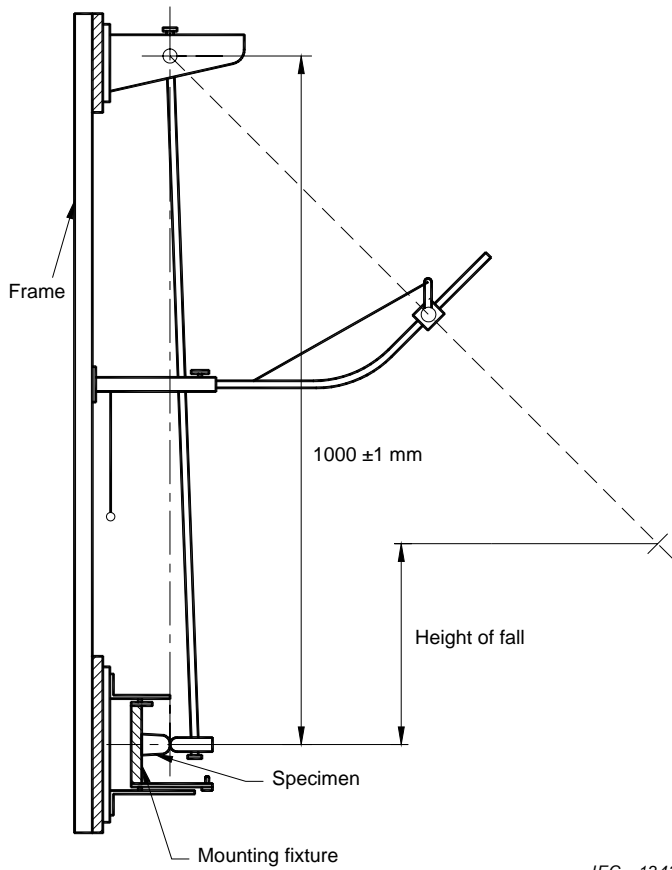

IEC 1243/04

Figure 8 – Impact-test apparatus

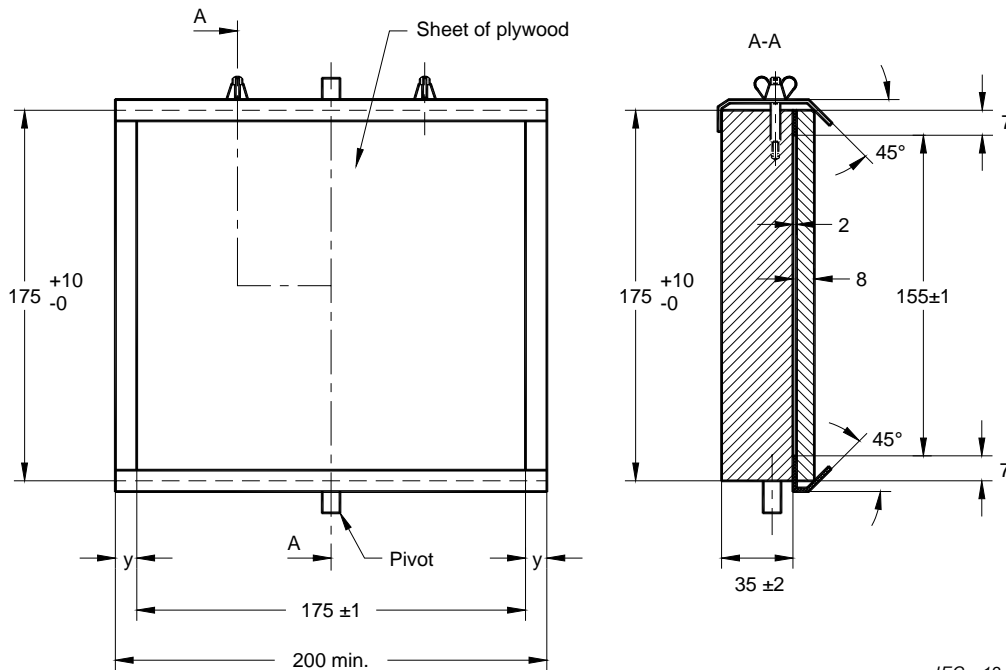

IEC 1244/04

NOTE For information this drawing has been retained in this standard, although there is a basic standard. In case of doubt regarding the drawing, refer to IEC 60068-2-75.

Figure 8a – Mounting support

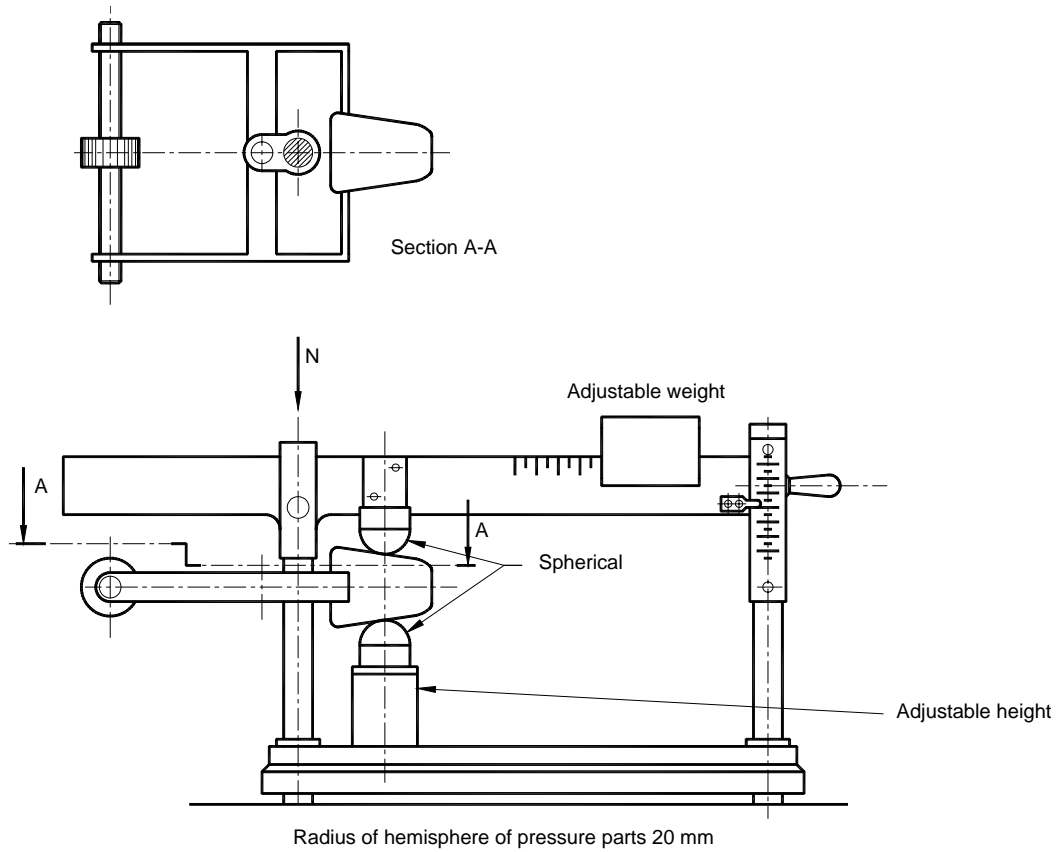

IEC 1245/04

**Figure 9 – Pressure apparatus**

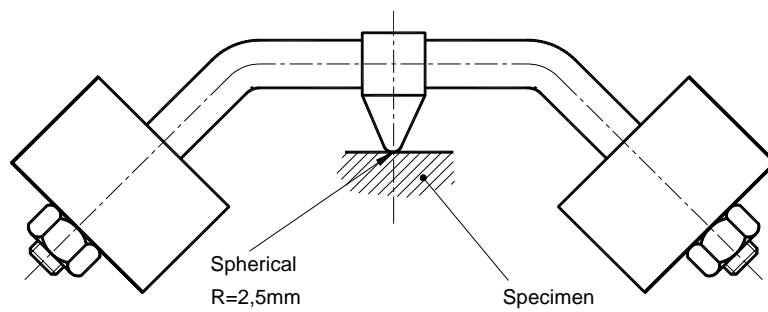

IEC 1246/04

**Figure 10 – Ball-pressure test apparatus**

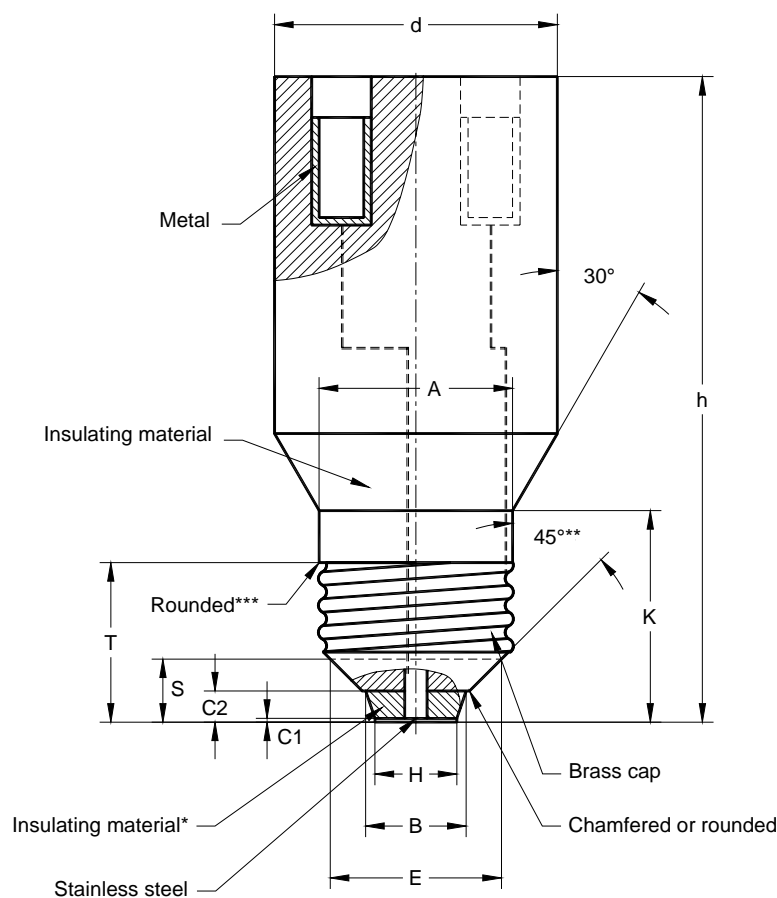

Tolerances for values without any indication:  
 - up to and including 30 mm : ± 0,05 ;  
 - over 30 mm : ±0,1 ;  
 - on angles: ±30'.

IEC 1247/04

\* The insulating material shall be such that it is dimensionally stable, easy to shape and having a PTI of 600; e.g. PTFE is a suitable material.

\*\* Refers to the metal part only; not applicable to test cap E10.

The dimensions of the thread on the test cap shall be between the maximum and minimum values specified for E10, E14, E27 and E40 caps in standard sheets 7004-22, 7004-23, 7004-21 and 7004-24 of IEC 60061-1 respectively. The inner diameter of the brass cap shall be 2 mm less than the dimension d1 indicated on the relevant standard sheet. The cross-sectional area of the conductors shall be 0,75, 1,5, 1,5 and 4,0 mm<sup>2</sup> for E10, E14, E27 and E40 respectively. The conductors shall be rigid (solid or stranded).

\*\*\* For the E14 test cap a 45° chamfer is required on the cylindrical portion of the gauge.

NOTE Values for E5 lampholders are under consideration.

Dimensions in millimetres

Lampholder	d	h	B	C1	C2	H	S	E	T min	K min	A max
E10	18	60	6	0,5	2,5	4	—	—	9,5	19	13
E14	38	80	9,5	0,5	3,8	6,2	4,5	12	16	27,2	17,1
E27	38	80	13,5	0,5	4,2	11,5	8,5	23	21,5	28,3	26,1
E40	55	100	25	1	8	18	10(1)	34(1)	34	47,8	39

(1) In case of lampholders E40, dimensions S and E are only needed for the design of the gauges.

Figure 11 – Test cap for the tests of 14.4 and 19.3

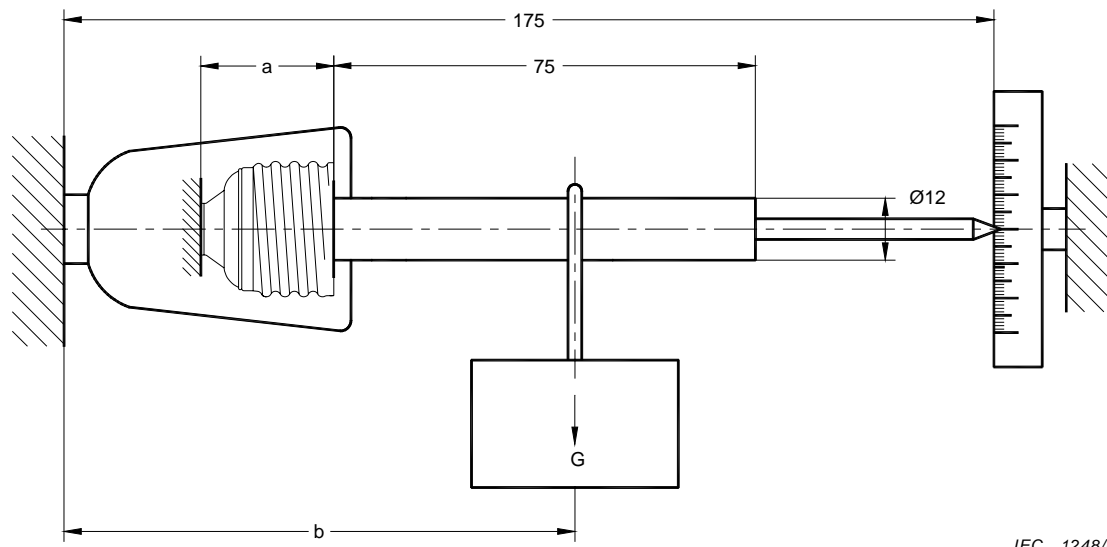

IEC 1248/04

Dimensions in millimetres

Lampholder	a	b	G kg
E14	19	100	1
E27	25	100	2
E40	37	140	3

Figure 12 – Bending apparatus

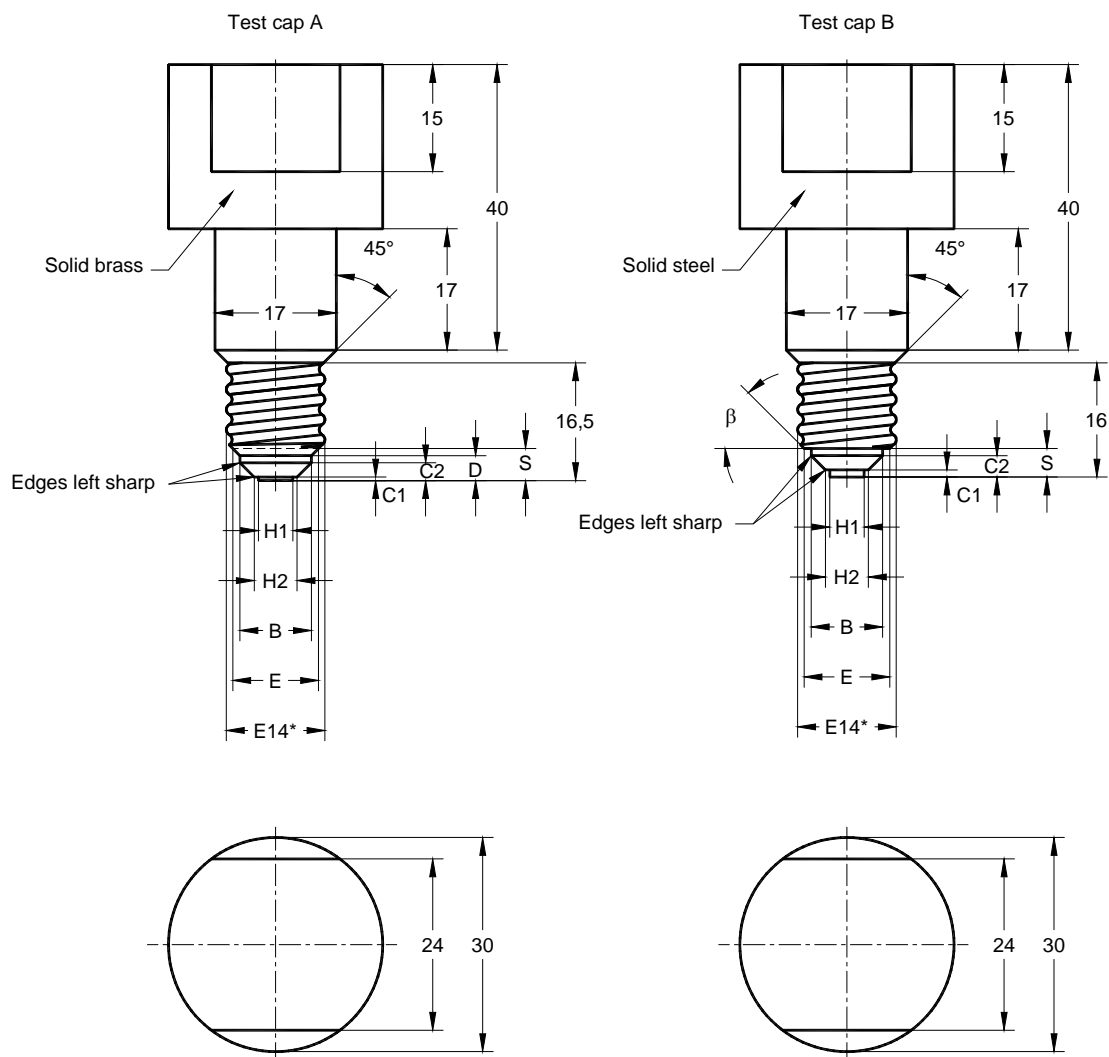

IEC 1249/04

The dimensions of the thread on test cap A shall be between the maximum and minimum values specified in standard sheet 7004-23 of IEC 60061-1.

The dimensions of the thread on test cap B shall be the minimum values, with a tolerance of  $\pm 0,05$  mm, specified in standard sheet 7004-23 of IEC 60061-1.

**Figure 13 – Test cap A and test cap B for lampholders E14**

*Dimensions in millimetres*

Reference	Dimensions		Tolerances	
	Test cap A	Test cap B	Test cap A	Test cap B
C1	0,5	1,0	+0,0 -0,1	+0,0 -0,1
C2	2,5	3,0	+0,0 -0,1	+0,0 -0,1
D	3,5	–	+0,1 -0,0	–
S	4,5	4,0	+0,06 -0,0	+0,0 -0,06
H1	4,8	4,8	+0,04 -0,04	+0,04 -0,04
H2	6	6	+0,04 -0,04	+0,04 -0,04
B	10	10	+0,04 -0,0	+0,06 -0,0
E	12	12	–	–
$\beta$	–	45°	–	+10' -10'

**Figure 13 – Test cap A and test cap B for lampholders E14 (continued)**

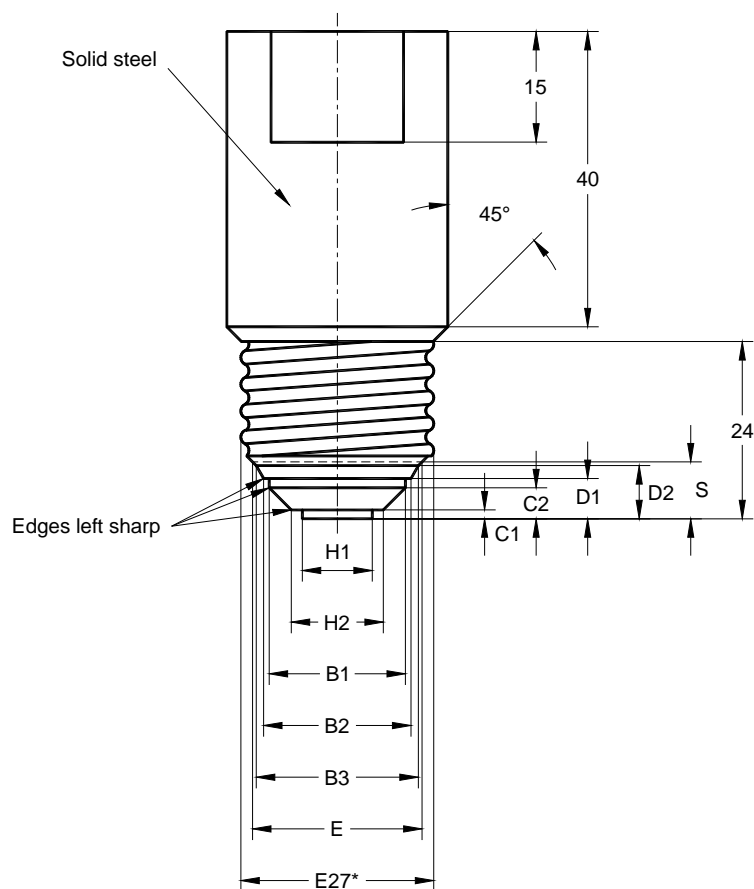

Reference	Dimension	Tolerance
C1	1,2	+0,0 -0,04
C2	4,2	+0,0 -0,06
D1	5,45	+0,1 -0,0
D2	7,2	+0,1 -0,0
S	7,7	+0,0 -0,04
H1	9,5	+0,04 -0,04
H2	12,5	+0,04 -0,04
B1	18,5	+0,06 -0,0
B2	20	+0,06 -0,0
B3	22	+0,06 -0,0
E	23	-

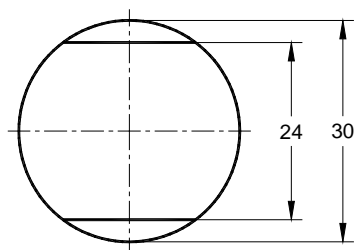

*Dimensions in millimetres*

\* The dimensions of the thread on the test cap shall be the minimum values, with a tolerance of  $\pm 0,05$  mm, specified in standard sheet 7004-21 of IEC 60061-1.

IEC 1250/04

**Figure 14 – Test cap for lampholders E27**

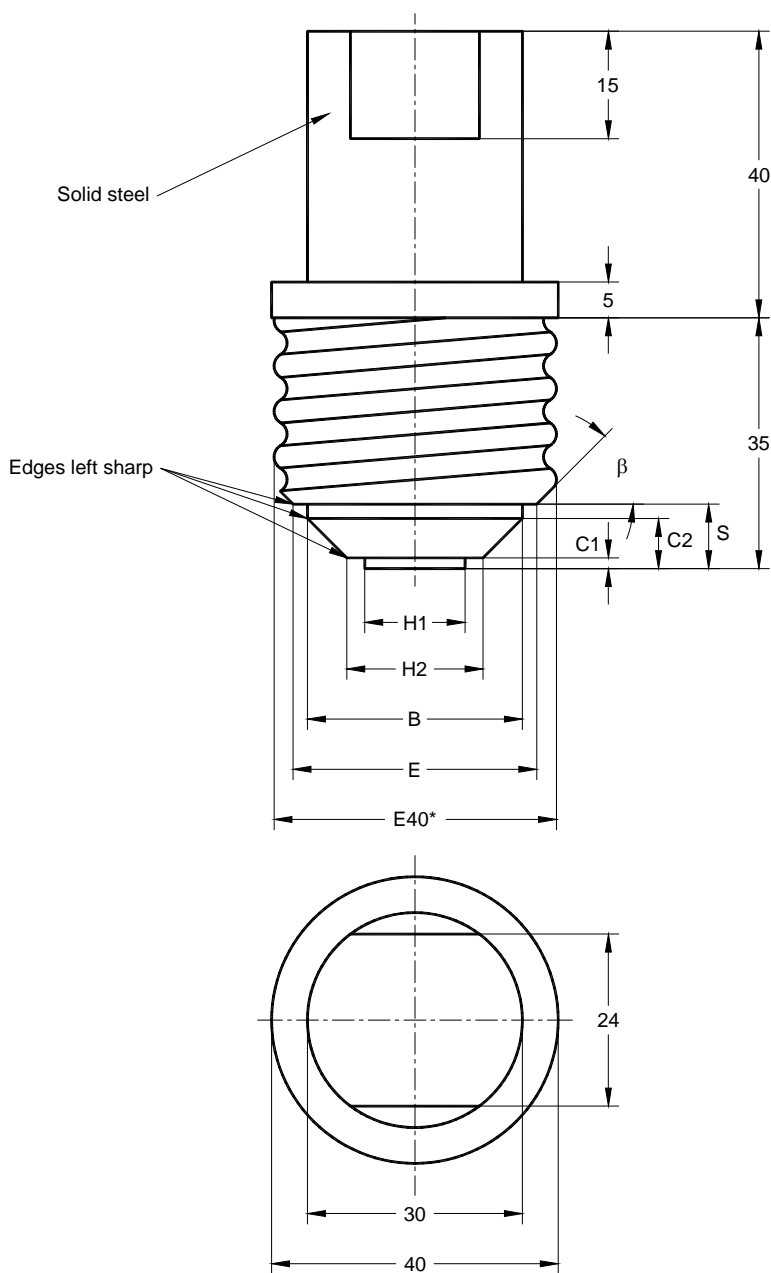

Reference	Dimension	Tolerance
C1	1,5	+0,0 -0,1
C2	7	+0,0 -0,1
S	9	+0,0 -0,06
H1	14	+0,04 -0,04
H2	19	+0,04 -0,04
B	30	+0,06 -0,0
E*	34	-
$\beta$	45°	+10' -10'

Dimensions in millimetres

\* The dimensions of the thread on the test cap shall be the minimum values, with a tolerance of  $\pm 0,05$  mm, specified in standard sheet 7004-24 of IEC 60061-1.

IEC 1251/04

Figure 15 – Test cap for lampholders E40

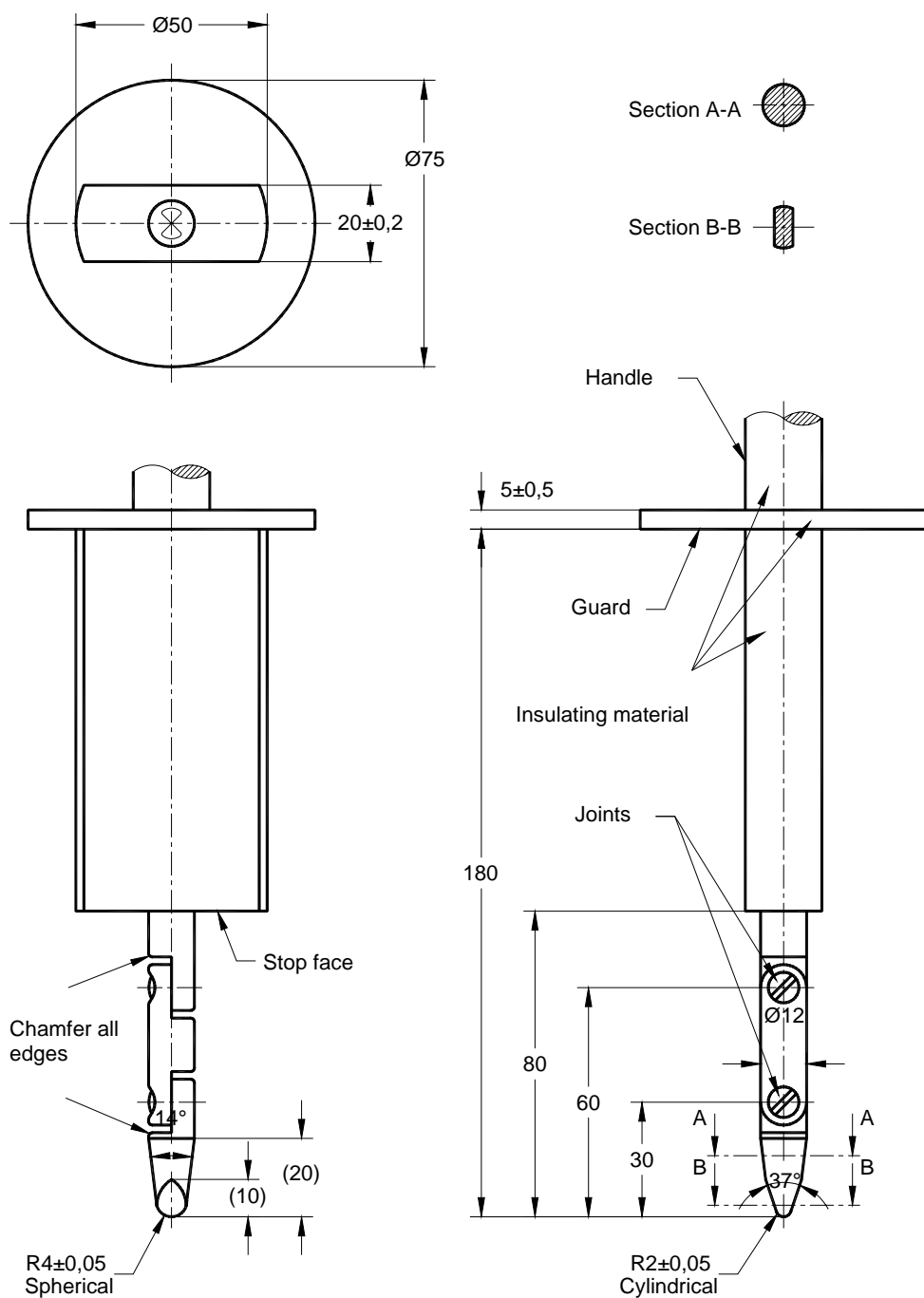

Material: metal, except where otherwise specified.

Linear dimensions in millimetres

Tolerances on dimensions without specific tolerance:

on angles: 0'–10'

on linear dimensions:

up to 25 mm: 0/–0,05 mm

over 25 mm: ±0,2 mm

Both joints shall permit movement in the same plane and the same direction through an angle of 90° with a 0° to +10° tolerance.

Figure 16 – Standard test finger (according to IEC 60529)

The drawings are intended only to show typical parts of a lampholder and should not limit the design.

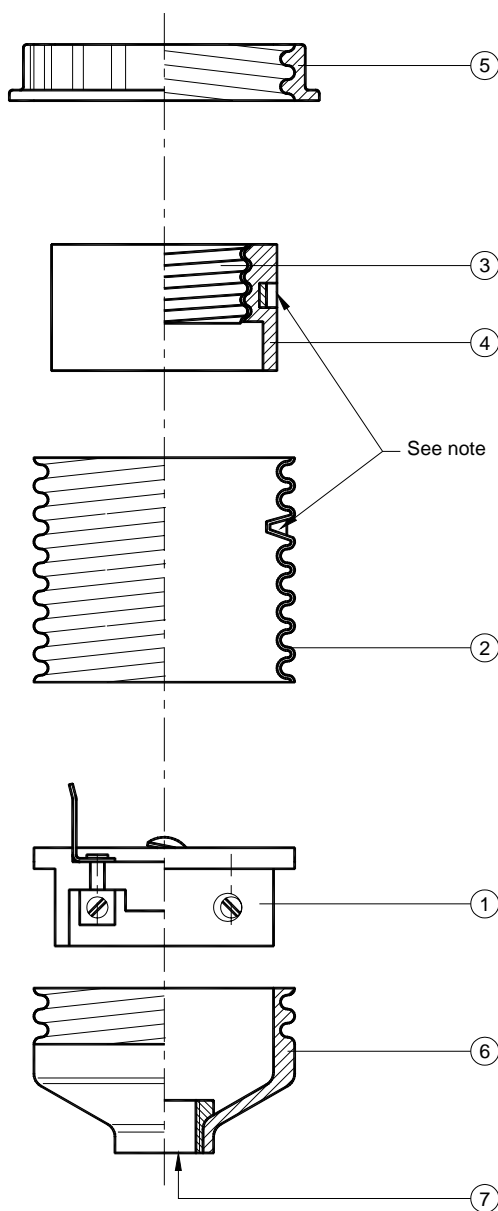

IEC 1253/04

NOTE In this example, parts 2, 3 and 4 are permanently connected together. In other constructions parts 1 and 3 may form one assembly.

- 1 Terminal/contact assembly
- 2 Outer shell
- 3 Screw shell
- 4 Insulating ring
- 5 Shade ring
- 6 Dome
- 7 Threaded entry

Figure 17 – Clarification of some definitions

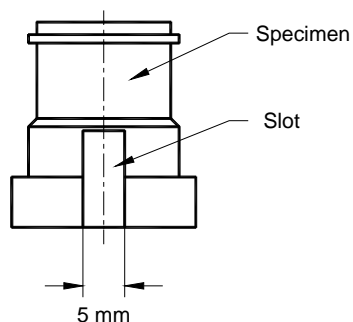

For E14 and E27 lampholders a slot having a width of 5 mm is made to allow entry of the needle and for ventilation. IEC 1254/04

For E40 lampholders no slot is required.

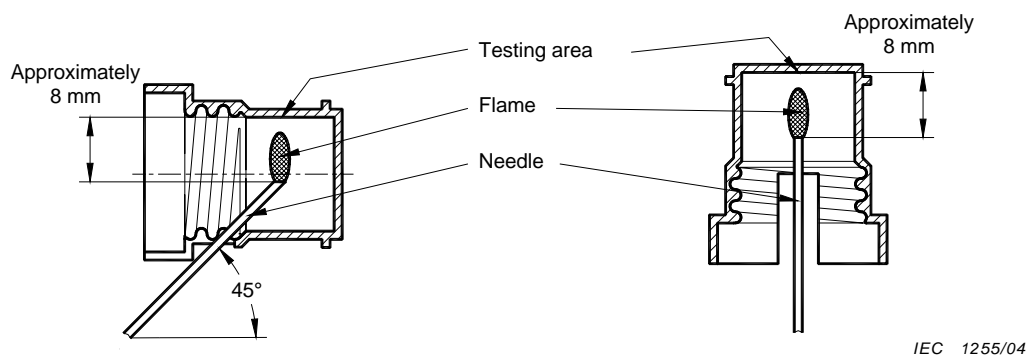

The left hand drawing shows how to perform the needle-flame test for testing the side-contact area (not applicable to lampholders E40).

The right-hand drawing shows how to perform the needle-flame test for testing the centre-contact area.

The minimum length of the needle is 35 mm.

**Figure 18 – Preparation of specimens for the needle-flame test of 20.4**



The preliminary draft of this standard has been developed by the work composed of

<b>Name</b>	<b>Agency</b>
1.Eng. Mohammed J. Yousef, MSLL, AMILE	Saudi Lighting Company Ltd.
3-Eng. Soliman M Elshahat	SASO-Riyadh

The draft standard was accepted for distribution to the concerned bodies in meeting No. of the Technical Committee No. (4) "lightings and Their Accessories" composed of the following.

<b>Name</b>	<b>Agency</b>
1-Dr. Mohammed Salah Simaie	King Abdul Aziz City for Sciences & Technology
2-Dr. Ibrahim Omar Habiballah	King Fahad University for Petroleum & Mineral
3-Eng. Mohammed J. Yousef Saleh	Saudi Lighting Company
4-Eng. Abbas Mohammad Abo Al-Naja	Ministry of Transportation
5-Dr. Rizk Elsayed	King saaud University –faculty of Engineering
6-Eng. Abdulrahman alfutni	Saudi airlines
7-Eng. Mohamed bazz	Saudi Electricity Company
8-Eng. Ibrahim Elmohani	SASO-Riyadh
9-Eng. Soliman M Elshahat	SASO-Riyadh