

**KINGDOM OF SAUDI ARABIA
SAUDI STANDARDS, METROLOGY AND QUALITY ORGANIZATION**

SASO

SAUDI STANDARD

DRAFT No19983 /2011

MEDICAL ELECTRICAL EQUIPMENT –

**Part 2-31: Particular requirements for the basic safety and essential
performance of external cardiac pacemakers with
internal power source**

SAUDI STANDARDS, METROLOGY AND QUALITY ORGANIZATION

THIS DOCUMENT IS A DRAFT SAUDI STANDARD CIRCULATED FOR COMMENT. IT IS, THEREFORE SUBJECT TO CHANGE AND MAY NOT BE REFERRED TO AS A SAUDI STANDARD UNTIL APPROVED BY THE BOARD OF DIRECTORS.

CONTENTS

INTRODUCTION	Error! Bookmark not defined.
201.1 Scope, object and related standards	4
201.2 Normative references	5
201.3 Terms and definitions	6
201.4 General requirements	7
201.5 General requirements for testing ME EQUIPMENT	8
201.6 Classification of ME EQUIPMENT and ME SYSTEMS	8
201.7 ME EQUIPMENT identification, marking and documents	8
201.8 Protection against electrical HAZARDS from ME EQUIPMENT	12
201.9 Protection against MECHANICAL HAZARDS of ME EQUIPMENT and ME SYSTEMS	13
201.10 Protection against unwanted and excessive radiation HAZARDS	13
201.11 Protection against excessive temperatures and other HAZARDS	13
201.12 Accuracy of controls and instruments and protection against hazardous outputs	14
201.13 HAZARDOUS SITUATIONS and fault conditions	18
201.14 PROGRAMMABLE ELECTRICAL MEDICAL SYSTEMS (PEMS)	18
201.15 Construction of ME EQUIPMENT	18
201.16 ME SYSTEMS	18
201.17 Electromagnetic compatibility of ME EQUIPMENT and ME SYSTEMS	18
202 Electromagnetic compatibility – Requirements and tests	18
Annexes	21
Annex AA (informative) Particular guidance and rationale	22
Bibliography	33
Index of defined terms used in this particular standard	34
Figure 201.101 – Measuring circuit for the PATIENT AUXILIARY CURRENT for ME EQUIPMENT with an INTERNAL ELECTRICAL POWER SOURCE	13
Figure 201.102 – Measuring circuit for the MAXIMUM TRACKING RATE	16
Figure 201.103 – Initial oscilloscope display when measuring MAXIMUM TRACKING RATE	16
Table 201.101 – Distributed ESSENTIAL PERFORMANCE requirements	8
Table 201.102 – DUAL CHAMBER connector terminal marking	9
Table 201.103 – Measurement method accuracy	15
Table 202.101 – Static discharge requirements	19
Table AA.1 – EXTERNAL PACEMAKER HAZARD inventory	23

INTRODUCTION

The Saudi Standards ,Metrology and Quality Organization (SASO) has adopted the International Standard IEC 60601-2-31/2008 “MEDICAL ELECTRICAL EQUIPMENT – Part 2-31: Particular requirements for the basic safety and essential performance of external cardiac pacemakers with internal power source” issued by the International Electro technical Commission (IEC). It has been adopted without any technical modifications with a view to its approval as a Saudi standard.

MEDICAL ELECTRICAL EQUIPMENT –**Part 2-31: Particular requirements for the basic safety and essential performance of external cardiac pacemakers with internal power source****201.1 Scope, object and related standards**

Clause 1 of the general standard¹⁾ applies, except as follows:

201.1.1 * Scope*Replacement:*

This International Standard applies to the BASIC SAFETY and ESSENTIAL PERFORMANCE of EXTERNAL PACEMAKERS powered by an INTERNAL ELECTRICAL POWER SOURCE, hereafter referred to as ME EQUIPMENT.

This standard applies to PATIENT CABLES as defined in 201.3. 109.

If a clause or subclause is specifically intended to be applicable to ME EQUIPMENT only, or to ME SYSTEMS only, the title and content of that clause or subclause will say so. If that is not the case, the clause or subclause applies both to ME EQUIPMENT and to ME SYSTEMS, as relevant.

HAZARDS inherent in the intended physiological function of ME EQUIPMENT within the scope of this standard are not covered by specific requirements in this standard except in 7.2.13 and 8.4.1 of the general standard.

NOTE See also 4.2 of the general standard.

This standard does not apply to the implantable parts of active implantable medical devices covered by ISO 14708-1 This standard does not apply to EXTERNAL PACEMAKERS which can be connected directly or indirectly to a SUPPLY MAINS.

This standard does not apply to transthoracic and oesophageal pacing ME EQUIPMENT and antitachycardia ME EQUIPMENT.

201.1.2 Object*Replacement:*

The object of this particular standard is to establish particular BASIC SAFETY and ESSENTIAL PERFORMANCE requirements for EXTERNAL PACEMAKERS AS DEFINED IN 201.3. 103.

201.1.3 Collateral standards*Addition:*

¹⁾ The general standard is IEC 60601-1:2005.

This particular standard refers to those applicable collateral standards that are listed in Clause 2 of the general standard and Clause 2 of this particular standard.

IEC 60601-1-3 does not apply.

201.1.4 Particular standards

Replacement:

In the IEC 60601 series, particular standards may modify, replace or delete requirements contained in the general standard as appropriate for the particular ME EQUIPMENT under consideration, and may add other BASIC SAFETY and ESSENTIAL PERFORMANCE requirements.

A requirement of a particular standard takes priority over the general standard.

For brevity, IEC 60601-1 is referred to in this particular standard as the general standard. Collateral standards are referred to by their document number.

The numbering of clauses and subclauses of this particular standard corresponds to that of the general standard with the prefix "201" (e.g. 201.1 in this standard addresses the content of Clause 1 of the general standard) or applicable collateral standard with the prefix "20x" where x is the final digit(s) of the collateral standard document number (e.g. 202.4 in this particular standard addresses the content of Clause 4 of the 60601-1-2 collateral standard, 203.4 in this particular standard addresses the content of Clause 4 of the 60601-1-3 collateral standard, etc.). The changes to the text of the general standard are specified by the use of the following words:

"Replacement" means that the clause or subclause of the general standard or applicable collateral standard is replaced completely by the text of this particular standard.

"Addition" means that the text of this particular standard is additional to the requirements of the general standard or applicable collateral standard.

"Amendment" means that the clause or subclause of the general standard or applicable collateral standard is amended as indicated by the text of this particular standard.

Subclauses or figures which are additional to those of the general standard are numbered starting from 201.101, additional annexes are lettered AA, BB, etc., and additional items aa), bb), etc.

Subclauses or figures which are additional to those of a collateral standard are numbered starting from 20x, where "x" is the number of the collateral standard, e.g. 202 for IEC 60601-1-2, 203 for IEC 60601-1-3, etc.

The term "this standard" is used to make reference to the general standard, any applicable collateral standards and this particular standard taken together.

Where there is no corresponding clause or subclause in this particular standard, the clause or subclause of the general standard or applicable collateral standard, although possibly not relevant, applies without modification; where it is intended that any part of the general standard or applicable collateral standard, although possibly relevant, is not to be applied, a statement to that effect is given in this particular standard.

201.2 Normative references

Clause 2 of the general standard applies, except as follows:

Replacement:

IEC 60601-1-2:2007, *Medical electrical equipment – Part 1-2: General requirements for basic safety and essential performance – Collateral standard: Electromagnetic compatibility - Requirements and tests*

Addition:

ISO 14708-2:2005, *Implants for surgery – Active implantable medical devices – Part 2: Cardiac pacemakers*

ANSI/AAMI PC69:2007, *Active implantable medical devices – Electromagnetic compatibility – EMC test protocols for implantable cardiac pacemakers and implantable cardioverter defibrillators*

NOTE Informative references are listed in the bibliography on page 33.

201.3 * Terms and definitions

For the purposes of this document, the terms and definitions given in IEC 60601-1:2005 and ISO 14708-2:2005 apply, except as follows:

NOTE An index of defined terms is found beginning on page 35.

*Addition:***201.3.101****ACTIVE IMPLANTABLE MEDICAL DEVICE**

active medical device which is intended to be totally or partially introduced, surgically or medically, into the human body or by medical intervention into a natural orifice, and which is intended to remain in place after the procedure

[ISO 14708-1:2000, definition 3.3]

201.3.102**BATTERY DEPLETION INDICATOR**

means of indicating when the battery should be replaced

201.3.103**CARDIAC PACEMAKER**

ME EQUIPMENT intended to treat bradyarrhythmias

201.3.104**DUAL CHAMBER**

relating to both atrium and ventricle

201.3.105**EXTERNAL PACEMAKER**

CARDIAC PACEMAKER with a NON-IMPLANTABLE PULSE GENERATOR and PATIENT CABLE(S) (if used)

201.3.106**LEAD**

flexible tube enclosing one or more insulated electrical conductors, intended to transfer electrical energy along its length between the EXTERNAL PACEMAKER and the patient's heart

[ISO 14708-1:2000, definition 3.5 modified]

201.3.107**MAXIMUM TRACKING RATE**

maximum PULSE RATE at which the IMPLANTABLE PULSE GENERATOR will respond on a 1:1 basis to a triggering signal

[ISO 14708-2:2005, definition 3.3.18]

201.3.108**NON-IMPLANTABLE PULSE GENERATOR**

ME EQUIPMENT with an INTERNAL ELECTRICAL POWER SOURCE which is intended for use outside the body and which produces a periodic electrical pulse intended to stimulate the heart through a LEAD (or combination of a LEAD and PATIENT CABLE)

201.3.109**PATIENT CABLE**

cable used to extend the distance between the NON-IMPLANTABLE PULSE GENERATOR and the pacing LEAD

201.3.110**POST-VENTRICULAR ATRIAL REFRACTORY PERIOD****PVARP**

atrial refractory period minus the AV delay

201.3.111**PRIMARY BATTERY**

one or more cells, which are not designed to be electrically recharged, that are fitted with devices necessary for use, for example case, terminals, marking and protective devices

[IEC 60050-482:2004, definition 482-01-04 modified]

201.3.112**SINGLE CHAMBER**

relating to either atrium or ventricle

201.4 General requirements

Clause 4 of the general standard applies, except as follows:

201.4.3 ESSENTIAL PERFORMANCE

Additional subclause:

201.4.3.101 Additional ESSENTIAL PERFORMANCE requirements

Additional ESSENTIAL PERFORMANCE requirements are found in the subclauses listed in Table 201.101.

Table 201.101 – Distributed ESSENTIAL PERFORMANCE requirements

Requirement	Subclause
BATTERY DEPLETION INDICATOR	201.11.8
ME EQUIPMENT parameter stability	201.12.1.101
PULSE AMPLITUDE stability	201.12.1.102
Disarming runaway rate protection	201.12.4.1
Deliberate action required to change settings	201.12.4.101
Parameter stability at onset of the BATTERY DEPLETION INDICATOR	201.12.4.102
Runaway protection	201.12.4.103
Interference reversion in the presence of sensed electrical interference	201.12.4.104
Limit at which the ventricle is paced in response to sensed atrial activity	201.12.4.105

201.4.10.1 Source of power for ME EQUIPMENT

Replacement:

ME EQUIPMENT shall be powered by a PRIMARY BATTERY.

Compliance is checked by inspection of the ACCOMPANYING DOCUMENTS.

201.4.10.2 Supply mains for ME EQUIPMENT and ME SYSTEMS

This subclause of the general standard does not apply.

201.4.11 * Power input

This subclause of the general standard does not apply.

201.5 General requirements for testing ME EQUIPMENT

Clause 5 of the general standard applies.

201.6 Classification of ME EQUIPMENT and ME SYSTEMS

Clause 6 of the general standard applies, except as follows:

201.6.2 * Protection against electric shock

Replacement:

ME EQUIPMENT shall be classified as INTERNALLY POWERED ME EQUIPMENT.

ME EQUIPMENT shall be recognized as INTERNALLY POWERED only if no external connections to an electrical power source are provided.

APPLIED PARTS shall be classified as TYPE CF APPLIED PARTS. APPLIED PARTS shall be classified as DEFIBRILLATION-PROOF APPLIED PARTS.

201.7 ME EQUIPMENT identification, marking and documents

Clause 7 of the general standard applies, except as follows:

201.7.2 Marking on the outside of ME EQUIPMENT or ME EQUIPMENT parts

Additional subclauses:

201.7.2.101 ME EQUIPMENT intended for SINGLE CHAMBER application

If the ME EQUIPMENT is intended for SINGLE CHAMBER applications, the connector terminals (if used) shall be conspicuously marked positive (+) and negative (-).

201.7.2.102 * ME EQUIPMENT intended for DUAL CHAMBER application

If the ME EQUIPMENT is intended for DUAL CHAMBER application, the connector terminals (if used) shall be marked according to Table 201.102. If colour is used to differentiate between channels in a DUAL CHAMBER application, then the ventricular channel should be marked with the colour white and the atrial channel should be marked with a contrasting colour.

Table 201.102 – DUAL CHAMBER connector terminal marking

Channel	Symbol		Terminal label
	Positive terminal	Negative terminal	
Atrial channel	A+	A-	ATRIUM
Ventricular channel	V+	V-	VENTRICLE

201.7.2.103 Bipolar connectors

When bipolar connectors are used, they shall have keyways that prevent inadvertent polarity reversal.

201.7.2.104 * Battery compartment

The means of access to the battery compartment shall be easily identifiable. The battery compartment shall be clearly and permanently marked with the IEC battery nomenclature, the voltage and type. The battery compartment shall be clearly and permanently marked to show the correct orientation of the battery or batteries.

201.7.4 Marking of controls and instruments

Additional subclauses:

201.7.4.101 * Control or indicator for pacing output

If constant current output is used, the control for selecting pacing output or the relevant indicating means shall be marked in terms of current in milliamperes (mA) through a resistive load of $500 \Omega \pm 1 \%$. If a constant voltage output is used, the pacing output or the relevant indicating means shall be marked in terms of volts (V) across a resistive load of $500 \Omega \pm 1 \%$.

201.7.4.102 * Control or indicator for PULSE RATE

The control for selecting PULSE RATE or the relevant indicating means shall be marked in terms of reciprocal minutes.

201.7.4.103 * Control for selecting pacing mode

If a means of selecting the pacing mode is provided, the ME EQUIPMENT shall indicate, as well as the mode selected, the possible pacing modes using the codes described in Annex DD of ISO 14708-2:2005.

201.7.9 ACCOMPANYING DOCUMENTS**201.7.9.2.2 * Warning and safety notices***Replacement:*

The instructions for use shall include all warning and safety notices.

NOTE General warnings and safety notices should be placed in a specifically identified section of the instructions for use. A warning or safety notice that applies only to a specific instruction or action should precede the instruction to which it applies.

The instructions for use shall provide the OPERATOR or RESPONSIBLE ORGANIZATION with warnings regarding any significant RISKS of reciprocal interference posed by the presence of the ME EQUIPMENT during specific investigations or treatments.

The instructions for use shall include the following:

- aa) * Warnings regarding potential changes in the behaviour of the pulse generator caused by electromagnetic or other interference sources (e.g. communication transmitters in hospitals, emergency transport vehicles, cellular telephones, etc.) and the effects of therapeutic and diagnostic energy sources (e.g. external cardioversion, diathermy, transcutaneous electrical nerve stimulators [TENS] devices, high-frequency surgical equipment, magnetic resonance imaging or similar sources) on the pulse generator. This shall include advice on recognizing when the behaviour of the pulse generator is being influenced by external interference sources and steps to be taken to avoid such interference.
- bb) * A warning about the danger of inadvertently introducing leakage current into the heart if supply mains-operated equipment is connected to the lead system.
- cc) * A warning that the patient cable shall be connected to the non-implantable pulse generator before the pacing leads are connected to the patient cable.
- dd) * A warning that when handling indwelling leads, the terminal pins or exposed metal are not to be touched nor be allowed to contact electrically conductive or wet surfaces.
- ee) * A warning regarding the HAZARDS of using PRIMARY BATTERIES other than those recommended by the manufacturer (for example, short battery life after the indication of low battery condition, degraded ME EQUIPMENT performance, overall reduced battery life, and erratic or no pacing).
- ff) * A warning that, before handling the external pulse generator, the patient cable or indwelling leads, steps shall be taken to equalize the electrostatic potential between the user and the patient, for example by touching the patient at a site remote from the pacing lead.
- gg) * A caution that, when clinically indicated, supplemental monitoring of the patient should be considered.

201.7.9.2.4 * Electrical power source*Replacement:*

The instructions for use shall contain advice on removal of the PRIMARY BATTERY if the ME EQUIPMENT is to be stored or when a long period of disuse is anticipated.

The instructions for use shall state the recommended primary battery specification.

The instructions for use shall contain the estimated service time from a fully charged battery at 20 °C ambient temperature when operating under specified conditions;

The instructions for use shall contain the estimated service time following activation of the BATTERY DEPLETION INDICATOR when operating under specified conditions.

The instructions for use shall contain the information (including a reference to the appropriate PRIMARY BATTERY specified in IEC 60086-2 [3]) giving the identity of the PRIMARY BATTERIES to be used so that they may be obtained from local sources.

201.7.9.2.5 ME EQUIPMENT description

Addition:

The instructions for use shall include the following:

- aa) * A general description, explanation of function available, and a description of each heart/PULSE GENERATOR interaction for each available pacing mode. See Annex DD.3 of ISO 14708-2:2005 for a description of pacing modes.
- bb) * The connector configuration, the geometry and/or dimensions of the receiving connectors and instructions for connecting the LEAD(S) OR PATIENT CABLE(S) to the NON-IMPLANTABLE PULSE GENERATOR.
- cc) * The electrical characteristics (including tolerances where applicable) at $20\text{ }^{\circ}\text{C} \pm 2\text{ }^{\circ}\text{C}$ with $500\ \Omega \pm 1\%$ load, unless otherwise stated, as follows:
 - ranges of BASIC, ESCAPE, MAXIMUM TRACKING and INTERFERENCE PULSE RATES (as applicable);
 - PULSE AMPLITUDE(S);
 - PULSE DURATION(S);
 - the SENSITIVITY range for both positive and negative polarities (if a sensing function is provided);
 - sensing amplifier blanking period(s) (if a sensing function is provided);
 - the REFRACTORY PERIOD(S) (pacing and sensing) and A-V INTERVAL(S) (as applicable);
 - mode of operation in the presence of sensed interference;
 - the rate limit (runaway protection), in reciprocal minutes.
- dd) * The electrical characteristics upon activation of the BATTERY DEPLETION INDICATOR (including tolerances where applicable, and measured at $20\text{ }^{\circ}\text{C} \pm 2\text{ }^{\circ}\text{C}$ with $500\ \Omega \pm 1\%$ load), including as applicable, unless these are unchanged from the values provided in 7.9.2.5 cc):
 - BASIC RATE or equivalent PULSE INTERVAL;
 - PULSE AMPLITUDES(s);
 - PULSE DURATION(s);
 - SENSITIVITY (if a sensing function is provided);
 - mode change (if applicable).

201.7.9.2.8 * Start-up PROCEDURE

Addition:

The instructions for use shall contain any environmental limitations regarding storing the EQUIPMENT immediately prior to use.

201.7.9.2.13 * Maintenance

Addition:

The instructions for use shall contain details for replacing the PRIMARY BATTERY and the means of ascertaining when replacement is required.

The instructions for use shall contain information calling the RESPONSIBLE ORGANIZATION'S attention to the need for periodic maintenance, as well as to the need for maintenance after any malfunction or accident of the ME EQUIPMENT irrespective of usage, especially:

- cleaning and disinfection of reusable PATIENT CABLES;
- cleaning and disinfection of the NON-IMPLANTABLE PULSE GENERATOR;
- inspection of cables and connections for possible defects, for example, loosening of connections and other wear and tear from such causes as PATIENT movement;
- inspection of the NON-IMPLANTABLE PULSE GENERATOR and PATIENT CABLE for signs of physical damage or contamination, in particular damage or contamination that can have a detrimental effect on the electrical isolation properties of the ME EQUIPMENT;
- functional checks, calibration, activation of keys, switches, etc., especially if the EQUIPMENT has suffered severe shock, for example, by being dropped.

201.8 Protection against electrical HAZARDS from ME EQUIPMENT

Clause 8 of the general standard applies, except as follows:

201.8.5.5 Defibrillation-proof applied parts

201.8.5.5.1 Defibrillation protection

Replacement:

The ME EQUIPMENT shall comply with 6.2.1 of ANSI/AAMI PC69:2007.

201.8.7.3 * Allowable values

Amendment:

In Table 3 [of IEC 60601-1:2005], replace the values for PATIENT AUXILIARY CURRENT for TYPE CF APPLIED PARTS for both d.c. and a.c. with 1 μ A in NORMAL CONDITION (NC) and 5 μ A in SINGLE FAULT CONDITION (SFC).

201.8.7.4 Measurements

201.8.7.4.1 General

Addition:



- aa) * *The NON-IMPLANTABLE PULSE GENERATOR output should be disabled during LEAKAGE CURRENT testing if possible. If the output is to be active, its contribution should not be considered part of the LEAKAGE CURRENT.*

201.8.7.4.8 * Measurement of the PATIENT AUXILIARY CURRENT

Replacement:

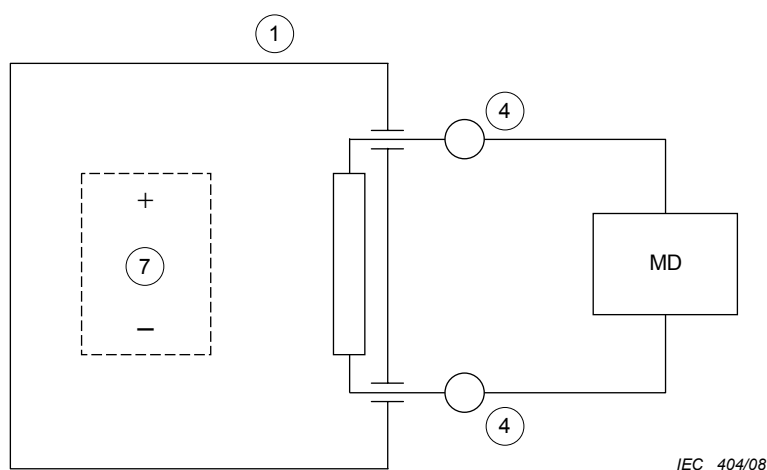
For measurement of PATIENT AUXILIARY CURRENT, the ME EQUIPMENT is connected as shown in Figure 201.101 to a d.c. measuring device with an input resistance of 100 k Ω . The ME EQUIPMENT shall be connected to the measuring device for a minimum of 5 min before making the PATIENT AUXILIARY CURRENT measurement. When measured just before the pacing pulse, the measured voltage shall not exceed 100 mV for NORMAL CONDITIONS and shall not exceed 500 mV for SINGLE FAULT CONDITION.

**Legend**

-  ME EQUIPMENT ENCLOSURE
-  PATIENT CONNECTIONS
-  INTERNAL ELECTRICAL POWER SOURCE
- MD Measuring device (see Figure 12 of IEC 60601-1:2005)

See also Table 5 of IEC 60601-1:2005.

Figure 201.101 – Measuring circuit for the PATIENT AUXILIARY CURRENT for ME EQUIPMENT with an INTERNAL ELECTRICAL POWER SOURCE

Additional subclause:

201.8.101 High-frequency surgical ME EQUIPMENT protection

The ME EQUIPMENT shall comply with 6.1.1 of ANSI/AAMI PC69:2007.

201.9 Protection against MECHANICAL HAZARDS of ME EQUIPMENT and ME SYSTEMS

Clause 9 of the general standard applies.

201.10 Protection against unwanted and excessive radiation HAZARDS

Clause 10 of the general standard applies.

201.11 Protection against excessive temperatures and other HAZARDS

Clause 11 of the general standard applies, except as follows:

201.11.6.5 * Ingress of water or particulate matter into ME EQUIPMENT and ME SYSTEMS

Replacement:

The EQUIPMENT shall be so constructed that, in the event of spillage of liquids (accidental wetting), no HAZARDOUS SITUATION shall result.

Compliance is checked by the following test:

The ME EQUIPMENT is placed in the least favourable position of NORMAL USE with the PATIENT CABLE attached. The ME EQUIPMENT is subjected to a spill of 400 ml of 9 g/l saline solution from a height of 30 cm. The entire 400 ml is poured over the ME EQUIPMENT in less than 5 s. Following the spill, the ME EQUIPMENT is not to be resting in a depth of more than 5 mm of saline solution.

Immediately after 30 s of exposure, the ME EQUIPMENT is removed from the saline solution and visible moisture on the outside of the ENCLOSURE is removed.

The ME EQUIPMENT is to operate within specification during and after the spill.

After at least 24 h have passed, the ME EQUIPMENT is to operate within specification. The ME EQUIPMENT is then disassembled and inspected. Any evidence that liquid has entered the electronic compartment constitutes a failure.

201.11.8 * Interruption of the power supply / SUPPLY MAINS to ME EQUIPMENT

Replacement:

The ME EQUIPMENT shall be equipped with a BATTERY DEPLETION INDICATOR which clearly indicates when the power source is to be replaced.

Compliance is checked by inspection and by functional test.

201.12 Accuracy of controls and instruments and protection against hazardous outputs

Clause 12 of the general standard applies, except as follows:

201.12.1 Accuracy of controls and instruments

Replacement:

201.12.1.101 * ME EQUIPMENT PARAMETERS

The measured values of the ME EQUIPMENT parameters shown in Table 201.103 shall be within the MANUFACTURER'S published tolerance when measured at PULSE RATE settings of 60 and 120 pulses per minute with a fully charged battery and the NON-IMPLANTABLE PULSE GENERATOR at $20\text{ }^{\circ}\text{C} \pm 2\text{ }^{\circ}\text{C}$. If 60 or 120 pulses per minute are not within the range for PULSE RATE settings for the ME EQUIPMENT, then the test shall be conducted at the minimum or maximum allowable settings.

Compliance is checked by either the appropriate methods described below and in 6.1 of ISO 14708-2:2005, or by any other method provided it can demonstrate an accuracy equal to or better than the accuracy listed in Table 201.103. In case of dispute, the test described below and in 6.1 of ISO 14708-2:2005 shall apply.

Table 201.103 – Measurement method accuracy

Measurement	Accuracy %
PULSE AMPLITUDE	±5
PULSE DURATION	±5
PULSE RATE	±0,5
SENSITIVITY (if applicable)	±10
ESCAPE interval	±10
REFRACTORY PERIOD(S) (if applicable)	±10
A.V. INTERVAL (if applicable)	±5
MAXIMUM TRACKING RATE (if applicable)	±0,5

Measurement of MAXIMUM TRACKING RATE is made using the following test.

With a fully charged battery and the NON-IMPLANTABLE PULSE GENERATOR in an A-V sequential mode with sensing and pacing in both chambers (DDD) at 20 °C ± 2 °C, the ME EQUIPMENT is connected according to Figure 201.102. The test apparatus is described in 6.1 of ISO 14708-2:2005. Adjust the signal generator until the amplitude of the test signal is approximately $2e_{pos}$ or $2e_{neg}$ as determined in 6.1.2 of ISO 14708-2:2005.

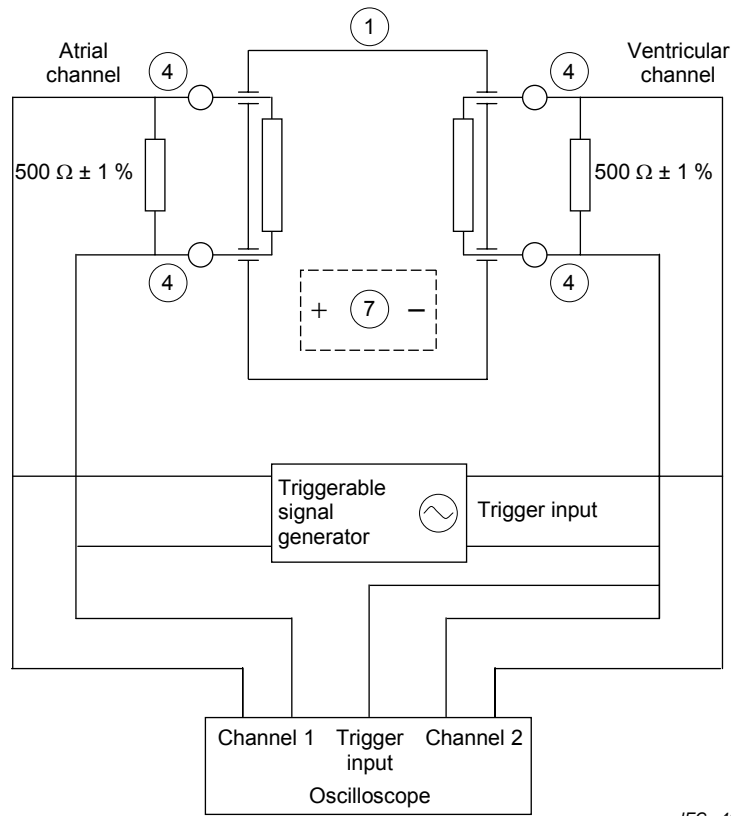

The delay from the triggering of the signal generator to the production of the test signal is designated D. Adjust the signal generator so that D is slightly greater than the POST-VENTRICULAR ATRIAL REFRACTORY PERIOD (PVARP). Slowly increase D until the ventricular pacing pulse just begins to track the additional delay as observed on Channel 2 of the oscilloscope. Measure the interval between sequential pacing pulses on Channel 2 in milliseconds. Designate that as interval T. Adjust the oscilloscope so that the display illustrated in Figure 201.103 is obtained.

$$\text{MAXIMUM TRACKING RATE [pulse per minute]} = 60\,000/T \text{ [ms]}$$



IEC 405/08

Legend

-  ME EQUIPMENT ENCLOSURE
-  PATIENT CONNECTIONS
-  INTERNAL ELECTRICAL POWER SOURCE

See also Table 5 of IEC 60601-1:2005.

Figure 201.102 – Measuring circuit for the MAXIMUM TRACKING RATE

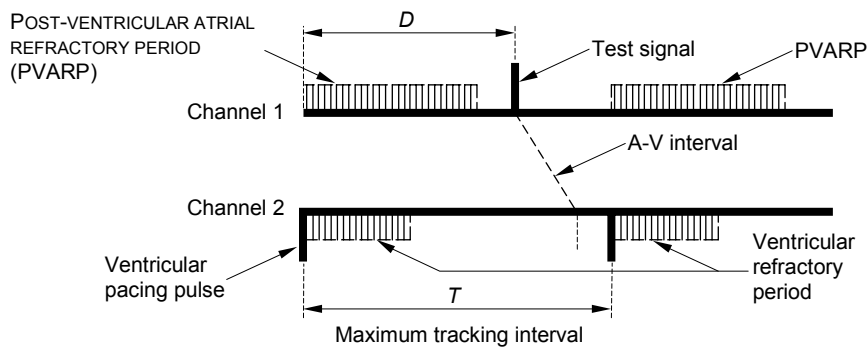

IEC 406/08

$D > PVARP$
 MAXIMUM TRACKING RATE [pulses per minute] = $60\,000/T$ [ms]

Figure 201.103 – Initial oscilloscope display when measuring MAXIMUM TRACKING RATE

201.12.1.102 * PULSE AMPLITUDE

The PULSE AMPLITUDE expressed either as voltage or current shall not vary from the indicated value by more than the percentage listed in the MANUFACTURER'S published specifications

when the load is varied from 200 Ω to 1 000 Ω , at a pacing rate of 70 pulses per minute with a fully charged battery, and the NON-IMPLANTABLE PULSE GENERATOR at 20 °C \pm 2 °C.

Compliance is checked by using the basic test method described in 6.1.1 of ISO 14708-2:2005 with test loads of 200 $\Omega \pm 1\%$ and 1 000 $\Omega \pm 1\%$ in order to determine how PULSE AMPLITUDE changes as a function of resistance.

201.12.4 Protection against hazardous output

201.12.4.1 * Intentional exceeding of safety limits

Replacement:

If the ME EQUIPMENT incorporates features which require PULSE RATES above the rate limit (see 12.4.103), the runaway rate protection may be disarmed when the feature is in use. The means for disarming the runaway rate protection shall require the OPERATOR to engage the activating mechanism continuously.

Compliance is checked by inspection and by a functional test.

Additional subclauses:

201.12.4.101 * Protection against accidental change of controls and tampering

Means shall be provided so that a deliberate action is required to change settings.

Compliance is checked by inspection.

201.12.4.102 * Protection against a low battery condition

Upon activation of the BATTERY DEPLETION INDICATOR, the measured values of the EQUIPMENT parameters listed in 7.9.2.5 dd) shall be within the MANUFACTURER'S published tolerance when measured with the NON-IMPLANTABLE PULSE GENERATOR at 20 °C \pm 2 °C with 500 $\Omega \pm 1\%$ load.

Compliance is checked by either the appropriate methods described in 6.1 of ISO 14708-2:2005, or by any other method provided it can demonstrate an accuracy equal to or better than the precision listed in Table 201.103. In case of dispute the test described in 6.1 of ISO 14708-2:2005 shall apply.

201.12.4.103 * Rate limit (runaway protection)

Means shall be provided to limit PULSE RATE, in the event of a SINGLE FAULT CONDITION, to the value specified by the MANUFACTURER.

Compliance is checked by inspection of the MANUFACTURER'S data.

201.12.4.104 * Interference reversion

In the presence of sensed electrical interference, the NON-IMPLANTABLE PULSE GENERATOR shall revert to a pacing mode and PULSE RATE specified by the MANUFACTURER until the interference stops.

Compliance is checked by inspecting the MANUFACTURER'S data.

201.12.4.105 * MAXIMUM TRACKING RATE

In DUAL CHAMBER modes incorporating atrial-synchronous ventricular pacing, a means shall be provided to set a limit at which the ventricle is paced in response to sensed atrial activity. The ME EQUIPMENT shall respond to sensed atrial activity above the MAXIMUM TRACKING RATE in a manner stated by the MANUFACTURER.

Compliance is checked by inspection and functional test.

201.13 HAZARDOUS SITUATIONS and fault conditions

Clause 13 of the general standard applies.

201.14 PROGRAMMABLE ELECTRICAL MEDICAL SYSTEMS (PEMS)

Clause 14 of the general standard applies.

201.15 Construction of ME EQUIPMENT

Clause 15 of the general standard applies, except as follows:

Additional subclauses:

201.15.101 * Output indicator

The ME EQUIPMENT shall incorporate a means to indicate when the ME EQUIPMENT has emitted a pacing PULSE.

Compliance is checked by inspection and functional test.

201.15.102 * Input indicator

If a sensing function is provided, the ME EQUIPMENT shall incorporate a means of indicating that the ME EQUIPMENT has detected signals and has responded to them as if they are associated with the electrical activity of the heart, and that it is reacting to the signals as specified by the MANUFACTURER for the selected pacing mode and other operational characteristics.

Compliance is checked by inspection and functional test.

201.16 ME SYSTEMS

Clause 16 of the general standard does not apply.

201.17 Electromagnetic compatibility of ME EQUIPMENT and ME SYSTEMS

Clause 17 of the general standard applies.

202 Electromagnetic compatibility – Requirements and tests

IEC 60601-1-2:2007 applies except as follows:

202.6.2.2 Electrostatic discharge (ESD)**202.6.2.2.1 * Requirements**

Replacement:

ME EQUIPMENT shall comply with the requirements of 6.2.1.10 [of IEC 60601-1-2:2007] as modified below at IMMUNITY TEST LEVELS specified in Table 202.101 for air discharge. For this requirement, the following conditions associated with BASIC SAFETY and ESSENTIAL PERFORMANCE shall apply:

- no permanent degradation or loss of function which is not recoverable, due to damage of ME EQUIPMENT (components) or software, or loss of data shall be observed at any IMMUNITY TEST LEVEL;
- no inappropriate delivery of energy to the PATIENT shall occur at any IMMUNITY TEST LEVEL;
- at IMMUNITY TEST LEVELS 1 or 2, the ME EQUIPMENT shall maintain normal performance within the specification limits;
- at IMMUNITY TEST LEVELS 3 or 4, the temporary degradation or loss of function or performance which requires operator intervention is acceptable.

Compliance is checked by application of the tests in 6.2.2.2. Evaluate the response of the ME EQUIPMENT or ME SYSTEM during and after these tests in accordance with 6.2.1.10 [of IEC 60601-1-2:2007] as modified above, considering each discharge individually.

202.6.2.2.2 Tests

Replacement:

The test methods and equipment specified by IEC 61000-4-2 apply, with the following modifications.

- a) The time between discharges is set to an initial value of 1 s. Longer time between discharges might be required in order to be able to distinguish between a response caused by a single discharge and a response caused by a number of discharges.*
- b) Air discharges are applied to non-conductive ACCESSIBLE PARTS of the ME EQUIPMENT or ME SYSTEM and conductive non-accessible portions of ACCESSIBLE PARTS. If the ME EQUIPMENT or ME SYSTEM is labelled with the IEC 60417-5134 symbol adjacent to a connector, that connector is exempt from this testing (see 5.1.2 and 5.2.1.2 [of IEC 60601-1-2:2007]).*
- c) ME EQUIPMENT is tested in such a way as to ensure that there is no appreciable charge retention between individual test discharges. The potential on the ME EQUIPMENT may be equalized with that of the ground plane, between individual test discharges, by temporarily grounding it through two 470 k Ω resistors connected in series. This potential equalization connection shall be disconnected and moved away from the ME EQUIPMENT during application of a test discharge.*

Table 202.101 – Static discharge requirements

IMMUNITY TEST LEVEL ^a	Test voltage kV	Number of single discharges
1	2	10
2	4	10
3	8	2
4	15	2

^a The IMMUNITY TEST LEVELS for air discharge are defined in Table 1 of IEC 61000-4-2.

Annexes

The annexes of the general standard apply except as follows:

Annex I

Annex I of the general standard does not apply.

Annex A (informative)

Particular guidance and rationale

A.1 General guidance

This annex explains the reason for the provisions of this particular standard in the IEC 60601 family, as useful background in reviewing, applying and revising the standard.

The rationale is directed towards those familiar with the subject of this standard but who have not participated in its development. Where the reason for a requirement is considered self-evident to such persons, reasons are not given. An understanding of the reasons for the main requirements is considered to be essential for proper application of the standard. Furthermore, as clinical practice and technology change, changes in this standard can be made with an understanding of previous concerns.

- **RISK ANALYSIS**

EXTERNAL PACEMAKERS are used to treat PATIENTS who have symptomatic or acute bradycardia as well as for temporary pacing related to other medical procedures. PATIENT safety is affected by the medical procedure involved, by the understanding of ME EQUIPMENT function by the clinician and by ME EQUIPMENT function. The requirements as specified in this particular standard are considered to provide for an acceptable RISK.

As a basis for establishing safety, an inventory of the RISKS to the PATIENT's safety posed by EXTERNAL PACEMAKERS was developed. The results of that analysis are summarized in Table AA.1. To facilitate the review of the document, a reference to the clause(s) in the standard where the action is described has been added to the table.

The tentative conclusion based on clinical experience is that failure to pace is the most probable occurrence of those HAZARDS listed.

Table AA.1 – EXTERNAL PACEMAKER HAZARD inventory

Hazard	Cause	Action	Reference in this standard	
FAILURE TO PACE Poor connection	Low battery	Battery indicator	201.11.8	
	Test of connection		201.7.9.2.13	
	Threshold rise	Clinical technique	Not applicable	
	Oversensing	Clinical technique	Not applicable	
	Fault	Stability of parameters with battery and depletion		201.7.9.2.5 dd) and 201.12.4.102
		Input indicator		201.15.102
		Defibrillator equipment protection		201.8.5.5.1
		High frequency surgical equipment protection		201.8.101
		Spillage protection		201.11.6.5
		Static electric discharges		202.6.2.2
Maintenance			201.7.9.2.13	
Maladjustment	Output indicator		201.15.101	
	Protective means		201.12.4.101	
	Marking of controls		201.7.4	
Electrode dislodgement	Clinical technique		Not applicable	
High rate	Fault	Rate limit (runaway protection)	201.12.4.103	
	Tampering	Protective means	201.12.4.101	
	Temporary high rate	Protective means	201.12.4.1	
	Atrial tachyarrhythmia	MAXIMUM TRACKING RATE	201.12.4.105	
Unwanted stimulation	Undersensing	Clinical technique	Not applicable	
		Stability of parameters with battery depletion	201.7.9.2.5 dd) and 201.12.4.102	
		Input indicator	201.15.102	
	Low battery	Battery indicator	201.11.8	
	Maladjustment	Protective means	201.12.4.101	
	Noise	Marking of controls	201.7.4	
		Noise reversions	201.7.9.2.5 cc) and 201.12.4.104	
		Warnings	201.7.9.2.2 aa)	
	Poor connection (lead or battery)	Test of connection	201.7.9.2.13	
	Fault	See failure to pace		
Microphonics	Noise reversion	201.7.9.2.5 cc) and 201.12.4.104		
Micro/Macro shock	Leakage current	Leakage current limit	201.6.2 and Clause 201.8	
	Injection current	Warning	201.7.9.2.2 aa), 201.7.9.2.2 bb), 201.7.9.2.2 cc), 201.7.9.2.2 dd), and 201.7.9.2.2 ff)	
Tissue/electrode damage	Patient auxiliary current	Patient auxiliary current limit	201.8.7.3	

A.2 Rationale for particular clauses and subclauses

The following are rationales for specific clauses and subclause in this particular standard, with clause and subclause numbers parallel to those in the body of the document.

Subclause 201.1.1 – Scope

The scope of this particular standard is restricted to EXTERNAL PACEMAKERS with an INTERNAL POWER SOURCE. This implies that all requirements in the general standard and collateral standards that apply to equipment connected to a SUPPLY MAINS are not applicable even though they are not specifically identified in this document.

The scope is restricted for the following reasons:

- The power source is restricted to INTERNAL ELECTRICAL POWER SOURCE, and in particular to PRIMARY BATTERIES, as the ME EQUIPMENT is intended to be moved with the PATIENT. ME EQUIPMENT that could be used when connected to SUPPLY MAINS or powered by rechargeable batteries would have intrinsically additional safety concerns, such as: difficulty in knowing length of service time, state of the battery (recharged or not), no applicable standards, etc.
- This standard excludes ME EQUIPMENT which can be directly or indirectly connected to SUPPLY MAINS.
- ME EQUIPMENT which provides pacing as one of several other functions requires separate treatment appropriate to its overall function.
- Transthoracic and oesophageal pacing ME EQUIPMENT provides higher output energies which would be inappropriate for direct cardiac pacing.
- Antitachycardia ME EQUIPMENT presents clinical safety issues which require separate treatment appropriate to its function.

PATIENT CABLES are included because they are commonly used as a means to extend the reach of the pulse generator while pacing the PATIENT during surgery, and for post-operative and extended pacing periods.

LEADS are not included because they require separate treatment appropriate to their type and their approach to the heart (transvenous, epicardial).

Clause 201.3 – Terms and definitions

The definitions from Clause 3 of ISO 14708-2 are referred to in order to encourage common usage worldwide for terms applicable to both IMPLANTABLE and EXTERNAL PACEMAKERS. Two definitions were copied from ISO 14708-1 for convenience.

Additional definitions have been added as needed to supplement those found in the ISO 14708 series. These definitions are based on common industry usage. Where possible, the definitions have been drawn from ACTIVE IMPLANTABLE MEDICAL DEVICES.

Subclause 201.4.11 – Power input

The requirements of this subclause are intended to apply to ME EQUIPMENT connected to SUPPLY MAINS, which does not apply to the EXTERNAL PACEMAKERS covered by this standard.

Subclause 201.6.2 – Protection against electric shock

ME EQUIPMENT is classified as being INTERNALLY POWERED EQUIPMENT only if there is no external connection to the INTERNAL ELECTRICAL POWER SOURCE, or the electrical connection to

the INTERNAL ELECTRICAL POWER SOURCE can be made only after physical and electrical separation of the INTERNAL ELECTRICAL POWER SOURCE from the remainder of the ME EQUIPMENT. ME EQUIPMENT not meeting this requirement is classified as CLASS I or CLASS II with an INTERNAL ELECTRICAL POWER SOURCE.

TYPE B APPLIED PART and TYPE BF APPLIED PART are deleted because only TYPE CF APPLIED PARTS are suitable for DIRECT CARDIAC APPLICATION.

Subclause 201.7.2.102 – ME EQUIPMENT intended for DUAL CHAMBER application

As an EXTERNAL PACEMAKER is frequently needed in an emergency situation, the information on making a correct connection to the LEADS has to be available without recourse to the INSTRUCTIONS FOR USE. Incorrect connecting of the output terminals or PATIENT connectors (i.e. atrial channel to ventricular leads) could result in inappropriate and potentially unsafe (high rate stimulation or inappropriate sensing, etc.) operation. Clear marking of both the polarity and chamber is required. If, in addition, colour is used to accentuate the difference, colours that can be differentiated regardless of colour perception (i.e., white and blue) should be used.

Subclause 201.7.2.104 – Battery compartment

Access to the battery compartment for replacement of the batteries is a common maintenance item. Quick identification of the correct type and the proper orientation of the batteries in the battery compartment are required to prevent extended loss of function and/or potential damage to the ME EQUIPMENT. An orientation for the batteries should be provided to avoid operator confusion even if the ME EQUIPMENT permits reversed connection.

Subclause 201.7.4.101 – Control or indicator for pacing output; and Subclause 201.7.4.102 – Control or indicator for pulse rate

Accurate setting of output energy levels and PULSE RATE is deemed to be essential to safe operation of the ME EQUIPMENT.

Subclause 201.7.4.103 – Control for selecting pacing mode

In order to convey clearly the primary intended use of a pulse generator, a three-letter code has been adopted. This is an adaptation of the code developed by the Heart Rhythm Society (formerly North American Society for Pacing and Electrophysiology) and the Heart Rhythm UK (formerly the British Pacing and Electrophysiology Group). To encourage common usage worldwide, the same code is used as that given in Annex DD of ISO 14708-2:2005 for IMPLANTABLE PULSE GENERATORS.

Subclause 201.7.9.2.2 – Warnings and safety notices

Subclause 201.7.9.2.2 aa)

Sources of electrical interference can affect the operation of the ME EQUIPMENT. In the presence of excessive levels of interference, the ME EQUIPMENT could:

- fail to pace,
- revert to asynchronous pacing, or
- inappropriately track the interference as cardiac activity.

Subclause 201.7.9.2.2 bb)

An implanted LEAD or LEAD with PATIENT CABLE constitutes a direct, low resistance current path to the myocardium. The danger of fibrillation resulting from alternating current leakage is greatly increased when SUPPLY MAINS operated ME EQUIPMENT is connected to the lead system. Extreme caution has to be taken to have proper grounding of SUPPLY MAINS operated ME EQUIPMENT used in the vicinity of the PATIENT.

Subclause 201.7.9.2.2 cc) and dd)

The PATIENT needs to be protected from electrical impulses inadvertently introduced by making contact with the terminals of the NON-IMPLANTABLE PULSE GENERATOR PATIENT CABLE and indwelling LEADS. Proper handling of the EQUIPMENT will reduce the chance of inadvertent shock while maintaining the clinically needed flexibility of connecting a variety of temporary LEADS, permanent LEADS, and heartwires to the PATIENT CABLE, or directly to the NON-IMPLANTABLE PULSE GENERATOR.

Subclause 201.7.9.2.2 ee)

Performance predictions, especially projections of life after the low battery indicator comes on, are dependent on an understanding of the depletion characteristics of the battery. Batteries with different physical dimensions can result in poor or intermittent contact.

Subclause 201.7.9.2.2 ff)

Although believed to be, at best, a rare complication of pacing, there is a theoretical possibility that a static discharge to the EXTERNAL PULSE GENERATOR or a PATIENT CABLE connected to it could transfer minimally sufficient energy to the PATIENT to produce cardiac depolarization. If this were to occur in an electrically unstable PATIENT during the vulnerable portion of the cardiac cycle, a potentially lethal arrhythmia might be induced. No documented cases or anecdotal reports of such an event are known. It should be noted that there are ways that one or more asynchronous pulses can be delivered to the patient (e.g. noise reversion, loss of sensing) all of which are much more likely and which typically are cautioned about in the labelling. While only rarely have these common occurrences precipitated an arrhythmia, medical literature leaves no doubt as to the potential for serious consequences. Therefore, a warning that care should be taken to discharge any static electricity that has accumulated on the attending health care professional or the PATIENT before touching the ME EQUIPMENT is appropriate.

Subclause 201.7.9.2.2 gg)

The pulse energy delivered to the PATIENT is a consequence of the setting of the EXTERNAL PULSE GENERATOR and interaction of that output with a dynamic PATIENT/LEAD environment. The acute load presented by the temporary PATIENT/LEAD system can vary over a range of several hundred ohms. While much of this variation might be clinically inconsequential, "significant" departures from the pre-set level of energy output can occur. Since what constituted a "significant" departure from the pre-set level of energy output will vary widely from PATIENT to PATIENT depending on many factors, including the pre-set margin of safety for capture, selecting a limit that could be monitored by the equipment and that would apply to all PATIENTS would necessarily leave other PATIENTS largely unprotected. The output circuitry cannot readily determine if the output resulted in capture of the heart.

Subclause 201.7.9.2.4 – Electrical power source

Well-made primary batteries do not leak under the recommended conditions of storage and use. All batteries, however, have a tendency to leak under some conditions. A leaking battery

can result in damage to the ME EQUIPMENT. Good practice would indicate that the battery should be removed if the ME EQUIPMENT is to be stored, or left for a period without use.

This edition of the standard is disallowing rechargeable batteries as the power source for the following additional risks associated with their use.

- Rechargeable batteries cannot be recharged indefinitely.
- Eventually, depending on battery chemistry and the pattern of charging and discharging, a rechargeable battery would no longer retain sufficient energy to meet the service life specified by the MANUFACTURER.
- A MANUFACTURER that specifies the use of rechargeable batteries would be required to provide instructions that enable the RESPONSIBLE ORGANIZATION to determine when the battery will no longer hold sufficient energy to meet the specified service life.

Service life estimate is based on batteries which are fully charged. Primary batteries should be fresh and fully charged as defined by the battery manufacturer or supplier.

An understanding of the service life of the ME EQUIPMENT after the onset of the low battery condition is important for establishing the urgency of replacing the power source when the low battery indicator is activated.

There is a wide variety of primary batteries, especially of the 9 V alkaline type, available. Use of batteries with different chemical characteristics from that recommended by the MANUFACTURER can result in: 1) a short battery life after onset of the low-battery indicator; 2) degraded NON-IMPLANTABLE PULSE GENERATOR performance; and/or 3) overall reduced battery life. Although IEC 60086-1 [2] gives recognized dimensions for 9 V batteries, there are many commonly available batteries which vary in size and terminal configuration. Use of batteries other than the ones specified by the MANUFACTURER can result in erratic or no pacing.

Subclause 201.7.9.2.5 – ME EQUIPMENT description

Subclause 201.7.9.2.5 aa)

Knowledge of pulse generator features and characteristics is necessary when selecting an EXTERNAL PACEMAKER for use on a PATIENT. Choosing between these features and characteristics requires that they be comparable, i.e. that they are based on common measurement techniques or common assumptions.

Subclause 201.7.9.2.5 bb)

NON-IMPLANTABLE PULSE GENERATORS and PATIENT CABLES are connected to a variety of LEADS with different LEAD connector pin configurations. The connector assembly grips the LEAD connector pin(s) with sufficient force to provide good electrical and mechanical connection. Knowledge of the design limits of the device can help prevent damage to the ME EQUIPMENT and failure to pace due to an inadequate connection.

Subclause 201.7.9.2.5 cc)

The electrical characteristics follow the outline established in 28.8.2 of ISO 14708-2:2005 for IMPLANTABLE PULSE GENERATORS. The test load of $500 \Omega \pm 1\%$ is the same value specified in ISO 14708-2 for IMPLANTABLE PULSE GENERATORS.

The operating temperature of $20\text{ }^{\circ}\text{C} \pm 2\text{ }^{\circ}\text{C}$ is a typical ambient operating temperature within the typical range suggested in the rationale for Subclause 7.9.3.1 of the general standard. The operating temperature of $20\text{ }^{\circ}\text{C} \pm 2\text{ }^{\circ}\text{C}$ is also the temperature under which primary battery discharge tests are to be carried out as specified in 6.2 of IEC 60086-1 [2].

Subclause 201.7.9.2.5 dd)

This requirement was taken from 28.19 d) of ISO 4708-2:2005 for IMPLANTED PULSE GENERATORS.

Subclause 201.7.9.2.8 – Start-up PROCEDURE

Adverse environmental conditions immediately prior to use can affect the reliable operation of the ME EQUIPMENT.

Subclause 201.7.9.2.13 – Maintenance

As reliable functioning of the ME EQUIPMENT is essential for the PATIENT's safety, these maintenance items are regarded as important.

Subclause 201.8.7.3 – Allowable values

A net direct current between electrodes in the body can result in damage to the tissue and the electrodes. Subclause 16.2 of ISO 14708-2:2005 requires that no PATIENT AUXILIARY CURRENT of more than 0,1 μA shall be detected in any current pathway. Since NON-IMPLANTABLE PULSE GENERATORS are used for relatively short periods of time, a higher level of PATIENT AUXILIARY CURRENT should be tolerated both under NORMAL (1 μA) and SINGLE FAULT (5 μA) conditions.

Subclause 201.8.7.4.1 – General**Subclause 201.8.7.4.1 aa)**

Due to capacitive coupling between the APPLIED PART and other parts, a certain amount of LEAKAGE CURRENT is unavoidable. During the pacing pulse, LEAKAGE CURRENTS can be higher, but will be much smaller than the intended pacing pulse current, and will not present a HAZARD to the PATIENT and the OPERATOR.

Subclause 201.8.7.4.8 – Measurement of the PATIENT AUXILIARY CURRENT

The test procedure is based on the one in 16.2 of ISO 14708-2:2005

The NON-IMPLANTABLE PULSE GENERATOR may provide a "recharge" pulse whose area (integral of amplitude over time) is equal to the pacing pulse and of opposite polarity. The purpose of a recharge pulse is to make the net current through the tissue and the lead zero. Since the "recharge" pulse would immediately follow the pace pulse, the measurement for PATIENT AUXILIARY CURRENT (d.c. offset) is performed just before the start of the pace pulse so that the "recharge" pulse is not included in the measurement.

Subclause 201.11.6.5 – Ingress of water or particulate matter into ME EQUIPMENT and ME SYSTEMS

The ME EQUIPMENT is likely to be used in close proximity to liquids which could be inadvertently spilled on the device while in operation, e.g. food and drink, urine, intravenous solutions, etc. The ME EQUIPMENT also has the potential to be carried and used outside medically used rooms. Therefore, a certain degree of protection against spillage and rainfall was deemed to be necessary.

Saline solution with a concentration of 9 g/l was selected as a worst case solution simulating body fluids. 400 ml was selected to simulate a filled large glass or coffee cup. Wiping the

ME EQUIPMENT dry after 30 s would be a normal response to a spill. The ME EQUIPMENT should continue to operate normally during and after the spill.

If saline penetrates the electronic compartment, undesired conduction paths or dendrites might develop within the circuitry. A 24 h delay between the solution exposure and the inspection was selected, so that sufficient time would pass for any saline that had entered the electronic compartment to migrate within the electronic compartment, and/or dendrites to develop.

Therefore, the integrity of the liquid ingress protection is assessed in two ways:

- 1) by assuring that the device function is not impaired during the spill (undesired conduction paths bridging intended conduction paths); and
- 2) visually by ensuring that no liquid, dendrites or stains are found in the electronics after the saline has had time to seep into and migrate within the electronic compartment.

Subclause 201.11.8 – Interruption of the power supply / SUPPLY MAINS to ME EQUIPMENT

The requirement for a BATTERY DEPLETION INDICATOR is essential to avoid unexpected change in characteristics or function caused by depletion of the battery.

Subclause 201.12.1.101 – ME EQUIPMENT parameters

The parameter measurement accuracies listed in Table 201.103 are based on data taken from 6.1 of ISO 14708-2:2005 which have been accepted as adequate for implantable pacemakers. The purpose of the test methods in 6.1 of ISO 14708-2:2005 are to allow overall assessment of NON-IMPLANTABLE PULSE GENERATOR function without elaborate instrumentation or equipment. The accuracies listed in Table 201.103 provide a "worst case" for comparing test methods to the methods listed in 6.1 of ISO 14708-2:2005.

The intention is that compliance be measured using the test similar to those specified in 6.1 of ISO 14708-2:2005 with fully charged batteries operating at 20 °C. A temperature of 20 °C ± 2 °C was selected for testing of the EQUIPMENT because it is:

- 1) a typical ambient temperature in medically controlled spaces; and
- 2) the temperature under which the discharge characteristics of the primary battery are determined according to 6.2 of IEC 60086-1 [2].

To test the parameter stability at different rates settings, values of 60 and 120 pulses per minute were selected as typical.

The test method for MAXIMUM TRACKING RATE is patterned on the test methods and uses the test apparatus and terminology described in 6.1 of ISO 14708-2:2005.

Subclause 201.12.1.102 – PULSE AMPLITUDE

Experience has shown that 200 Ω to 1 000 Ω represents the range of lead impedances, including the heart tissue, which are likely to be encountered in temporary pacing. 500 Ω is the typical value. Variation due to changing load is to be measured at a fixed pacing rate. A rate of 70 pulses per minute was selected as a common rate available in all devices.

Subclause 201.12.4.1 – Intentional exceeding of safety limits

If high pacing rates are used in specific circumstances, extra precautions should be taken to prevent accidental high rate stimulation and to prevent the ME EQUIPMENT from being inadvertently left with the runaway rate protection feature disabled.

Subclause 201.12.4.101 – Protection against accidental change of controls and tampering

Maladjustment of the controls can result in a hazard, therefore appropriate steps should be taken to reduce this possibility.

Subclause 201.12.4.102 – Protection against a low battery condition

The published tolerances listed in 7.9.2.5 cc) are intended to extend over the service life of the power source, from fully charged to the detection of the low battery condition. If the ME EQUIPMENT changes its behaviour or is unable to maintain the tolerances listed in 7.9.2.5 cc), the new behaviour is described in 7.9.2.5 dd) and tested using the same test methods as those used to characterize the electrical parameters listed in 7.9.2.5 cc).

Subclause 201.12.4.103 – Rate limit (runaway protection)

This feature is required in order to prevent unexpected and dangerously high pacing rates from occurring in the event of a SINGLE FAULT CONDITION.

Subclause 201.12.4.104 – Interference reversion

The ME EQUIPMENT during NORMAL USE might be used in areas where strong continuous electrical interference is present. For maximum safety under these conditions, the ME EQUIPMENT should revert to a stated mode of operation until the interference stops.

Subclause 201.12.4.105 – MAXIMUM TRACKING RATE

If DUAL CHAMBER modes incorporating atrial-synchronous ventricular pacing are available in the ME EQUIPMENT, a means should be provided to limit the ventricular pacing rate in response to sensed atrial activity to prevent deterioration of the haemodynamic state of the PATIENT. This value is independent of the runaway limit which is intended to prevent an excessively high pacing rate in the event of a SINGLE FAULT CONDITION.

Subclause 201.15.101 – Output indicator

An output indicator is a quick non-invasive indication of device operation. However, a circuit which monitors the actual output pulse cannot readily determine if that output resulted in capture of the heart. Determining proper ME EQUIPMENT function and capture of the heart requires expert examination of the electrocardiogram.

Subclause 201.15.102 – Input indicator

An input indicator provides an indication that the device has detected the electrical activity of the heart and will react to the signal as specified by the MANUFACTURER for the selected pacing mode and other operational characteristics of the ME EQUIPMENT.

Subclause 202 – Electromagnetic compatibility – Requirements and tests**Subclause 202.6.2.2 – Electrostatic discharge (ESD)****Subclause 202.6.2.2.1 – Requirements**

EXTERNAL PACEMAKERS are used in environments where no special precautions have been taken to reduce the probability and magnitude of static discharges, such as humidity controlled rooms, static treated carpets, etc. In these conditions the ME EQUIPMENT is likely to

be exposed to static discharges which could damage an unprotected device. Severity level 4 was chosen as the maximum test level because 15 kV is a practically achievable value for the electrostatic voltage to which the operator might be charged. See Figure A.1 in IEC 61000-4-2.

The AIR DISCHARGE METHOD was chosen because a likely scenario has the USER walking across a tiled or carpeted floor and then discharging to the EQUIPMENT through an air gap as he reaches for the device.

Multiple discharges are needed to test ESD effects on timing sequences within the device, especially where microprocessors and software are involved. Subclause 8.3.1 of IEC 61000-4-2 specifies at least ten single discharges. This number should be increased as device complexity increases. At the higher voltage levels, the number of discharges is decreased to two out of concern for inducing errors due to the testing rather than simulation of the environment, since the probability of higher voltages occurring is lower than the probability of the lower voltage levels. Also, because the probability of the higher voltages is lower, some temporary degradation requiring operator intervention or system reset is allowed at severity levels 3 and 4.

Bibliography

- [1] ISO 14708-1:2000, *Implants for surgery – Active implantable medical devices – Part 1: General requirements for safety, marking and for information to be provided by the manufacturer*
- [2] IEC 60086-1:2006, *Primary batteries – Part 1: General*
- [3] IEC 60086-2:2006, *Primary batteries – Part 2: Physical and electrical specifications*

Index of defined terms used in this particular standard

ACCESSIBLE PART	IEC 60601-1:2005, 3.2
ACTIVE IMPLANTABLE MEDICAL DEVICE	201.3. 101
APPLIED PART	IEC 60601-1:2005, 3.8
BATTERY DEPLETION INDICATOR	201.3.102
CARDIAC PACEMAKER	201.3.103
CLASS I	IEC 60601-1:2005, 3.13
CLASS II	IEC 60601-1:2005, 3.14
DIRECT CARDIAC APPLICATION	IEC 60601-1:2005, 3.22
DUAL CHAMBER	201.3.104
EXTERNAL PACEMAKER	201.3.105
HAZARD	IEC 60601-1:2005, 3.39
IMMUNITY TEST LEVEL	IEC 60601-1-2:2007, 3.15
INTERNAL ELECTRICAL POWER SOURCE	IEC 60601-1:2005, 3.45
INTERNALLY POWERED	IEC 60601-1:2005, 3.46
LEAD	201.3.106
LEAKAGE CURRENT	IEC 60601-1:2005, 3.47
MANUFACTURER	IEC 60601-1:2005, 3.55
MAXIMUM TRACKING RATE	201.3.107
MEDICAL ELECTRICAL EQUIPMENT (ME EQUIPMENT)	IEC 60601-1:2005, 3.63
MEDICAL ELECTRICAL SYSTEM (ME SYSTEM)	IEC 60601-1:2005, 3.64
NON-IMPLNATABLE PULSE GENERATOR	201.3.108
OPERATOR	IEC 60601-1:2005, 3.73
PACEMAKER	ISO 14708-2:2005, 3.3.2
PATIENT	IEC 60601-1:2005, 3.76
PATIENT AUXILIARY CURRENT	IEC 60601-1:2005, 3.77
PATIENT CABLE	201.3.109
POST-VENTRICULAR ATRIAL REFRACTORY PERIOD (PVARP)	201.3.110
PRIMARY BATTERY	201.3.111
PROCEDURE	IEC 60601-1:2005, 3.88
PULSE	ISO 14708-2:2005, 3.3.6
PULSE AMPLITUDE	ISO 14708-2:2005, 3.3.7
PULSE RATE	ISO 14708-2:2005, 3.3.15
RISK	IEC 60601-1:2005, 3.102
RISK ANALYSIS	IEC 60601-1:2005, 3.103
SINGLE CHAMBER	201.3.112
SINGLE FAULT CONDITION	IEC 60601-1:2005, 3.116
SUPPLY MAINS	IEC 60601-1;2005, 3.120
TYPE B APPLIED PART	IEC 60601-1:2005, 3.132
TYPE BF APPLIED PART	IEC 60601-1:2005, 3.133
TYPE CF APPLIED PART	IEC 60601-1:2005, 3.134